The Velocity of the Ions Produced in Gases by Rontgen Rays

John Zeleny

Phil. Trans. R. Soc. Lond. A 1900 **195**, 193-234

doi: 10.1098/rsta.1900.0026

Email alerting service

Receive free email alerts when new articles cite this article - sign up in the box at the top right-hand corner of the article or click [here](#)

To subscribe to *Phil. Trans. R. Soc. Lond. A* go to: <http://rsta.royalsocietypublishing.org/subscriptions>

V. *The Velocity of the Ions produced in Gases by Röntgen Rays.*

By JOHN ZELENY, *B.Sc., B.A., Assistant Professor of Physics, University of Minnesota.*

Communicated by Professor J. J. THOMSON, F.R.S.

Received February 5,—Read March 1, 1900.

§ 1. INTRODUCTION.

THE electrical conductivity which is imparted to gases by their exposure to Röntgen rays has been explained by J. J. THOMSON and E. RUTHERFORD* on the hypothesis of a formation of oppositely charged carriers throughout the volume of the gas. The motion of these carriers or ions when in an electric field constitutes the observed conductivity, and the recovery of the insulating property of a gas after an exposure to the rays is due partly to the recombination of the oppositely charged ions and partly to their impact with the boundaries.

An estimate of the sum of the velocities with which the positive and negative ions move in air when in a unit electric field was first obtained by J. J. THOMSON and E. RUTHERFORD, and later E. RUTHERFORD,† by the same indirect method, determined the sum of the velocities of the ions in a number of gases. This method involved the determination of the rate of recombination of the ions, the saturation current obtained through the gas by the use of a strong electric field, and the current obtained with some small non-saturating electric force. E. RUTHERFORD also describes an experiment in which the velocities of the two ions in air were obtained separately by a direct method, and found to be approximately equal. The writer‡ has since shown that in general the two velocities are not equal, and for those gases for which the ratio of the two velocities was determined the negative ion moved the faster in nearly all cases.

The values of the velocities of the ions have recently been applied by J. J. THOMSON§ and J. S. TOWNSEND|| in the determination of important physical quantities, and it seemed desirable that a redetermination of the values of the velocities be

* J. J. THOMSON, and E. RUTHERFORD, 'Phil. Mag.,' November, 1896

† E. RUTHERFORD, 'Phil. Mag.,' November, 1897

‡ J. ZELENÝ, 'Phil. Mag.,' July, 1898.

§ J. J. THOMSON, 'Phil. Mag.,' December, 1898.

|| J. S. TOWNSEND, 'Phil. Trans.,' A, vol. 193, 1899.

undertaken, partly because of advances in our understanding of some of the intricacies of the conduction, and partly because it seemed desirable that a satisfactory direct method be devised whereby the velocities of the two ions could be determined separately, and in which the experimental conditions could be subjected to a number of variations sufficient to ensure freedom from serious errors.

In undertaking this, an attempt was first made to use a modification of the method employed by the writer in the determination of the ratio of the two ionic velocities, which is described in a previous paper. The ions were made to go against a stream of gas in a tube by means of an electric field, and their velocity was compared to that of the gas stream. The presence of the gauzes necessary for the production of the electric field was found, however, to disturb the gas stream sufficiently to produce a turbulent motion in it and so prevented the attainment of absolute results.

The method which was then developed, and the one with which all of the results of this paper were obtained, also consisted in directly comparing the ionic velocity with that of a stream of gas, but avoided the difficulty of the above by having the electric field at right angles to the gas stream.

§ 2. THE METHOD USED FOR DETERMINING THE VELOCITY.

A stream of gas is passed between two concentric cylinders which are kept at different potentials, and which at one place are traversed by a beam of Röntgen rays. The ions which are produced between the two cylinders by the rays are carried along by the stream of gas and at the same time, under the influence of the electric force, they move at right angles to the axis of the tubes. The resultant paths of the ions are inclined by an amount depending upon the relative value of the velocity of the gas stream to that of the ions.

Let CC' in fig. 1 represent a section of a portion of the outer cylinder, and DB that of the inner one, and let dd represent a narrow beam of rays traversing the two cylinders at right angles to their common axis. When the two cylinders are at

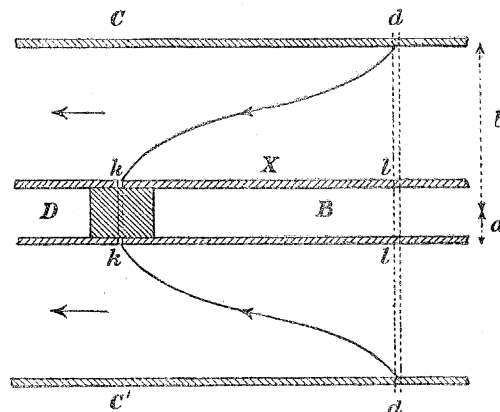

Fig. 1.

different potentials and the gas between them is at rest, an ion starting from the point d at the inner surface of the outer cylinder will move directly across to l under the electric force. But when a stream of gas is passing between the cylinders from right to left, the ion will also be carried along by the stream, and so follow a path somewhat like that represented by the curve dk , finally reaching the inner cylinder at some point, k , which can be determined. The paths of the ions are not straight lines, because the electric intensity and the velocity of the gas stream vary from point to point between the cylinders and according to a different law for each. The distance X that the ions have been carried along the tube by the gas stream while they are crossing between the two cylinders under the electric force is a measure of the relative velocities of the gas and of the ions, and so may be used in determining the velocity with which the ions move in a given electric field.

Let the outer cylinder be kept at a potential of A volts and the inner one at zero potential.

Let b be the inner radius of the outer cylinder and a the outer radius of the inner cylinder.

Then the potential at any point between the cylinders at a distance r from the common axis of the two cylinders is

$$R = \frac{A \log_e r/a}{\log_e b/a} \dots \dots \dots (1),$$

and the electric intensity at this point is

$$\frac{dR}{dr} = \frac{A}{r \log_e b/a} \dots \dots \dots (2).$$

If we let v represent the velocity with which an ion moves when in an electric field whose intensity is 1 volt per centim., and assume that its velocity is proportional to the strength of the field, then at a point whose electric intensity is represented by equation (2), the radial velocity of the ion will be

$$V = \frac{Av}{r \log_e b/a} \dots \dots \dots (3).$$

The ion being carried by the moving gas also has a motion along the tubes. The velocity of the gas stream at any point depends upon its distance from the axis of the cylinders, which will be called the x axis.

Suppose that at the distance r from this axis the gas velocity is u .

The motion of the ion is represented by

$$\frac{dx}{dr} = \frac{u}{V} \dots \dots \dots (4),$$

and substituting the value of V from (3),

$$dx = \frac{ur \log_e b/a}{Av} dr \dots \dots \dots (5).$$

The distance X travelled by the ion in the direction of the x axis while it is traversing the whole distance between the cylinders, *i.e.*, from $r = b$ to $r = a$, is

$$X = \frac{\log_e b/a}{Av} \int_a^b u r dr \quad \dots \quad (6).$$

Now the average velocity of the gas stream as measured by the quotient of the total volume of gas emitted in a second by the area of the cross section is

$$U = \frac{2}{b^2 - a^2} \int_a^b u r dr \quad \dots \quad (7).$$

From (6) and (7)

$$X = \frac{U(b^2 - a^2)}{2Av} \log_e \frac{b}{a} \quad \dots \quad (8), \quad \text{and} \quad v = \frac{U(b^2 - a^2)}{2AX} \log_e \frac{b}{a} \quad \dots \quad (9).$$

This gives the value of the ionic velocity in a unit field in terms of quantities which can be experimentally determined.

The time required for the ions to pass from one cylinder to the other is

$$T = \int_a^b \frac{dr}{v} = \frac{\log_e b/a}{Av} \int_a^b r dr = \frac{(b^2 - a^2)}{2Av} \log_e \frac{b}{a} = \frac{X}{U} \quad \dots \quad (10).$$

The equations above apply to ions starting from the inner surface of the outer cylinder and moving inward to the inner cylinder. In practice it is not possible to limit the production of the ions by the Röntgen rays to the inner surface of the outer cylinder, so a narrow beam of rays is passed at right angles through the cylinders, as is represented by dd of fig. 1. Of the ions of this layer which move inward under the influence of the electric force, those that start from the circumference at d are carried the farthest by the gas stream before they reach the inner cylinder. Under these conditions the equations obtained can be applied by determining the point along the inner cylinder farthest from the beam of rays that is still reached by ions. For obtaining this point, the inner cylinder DB is divided at k into two parts, insulated from each other, the part B to the right being connected to earth, while the part D , to the left of the division at k , is connected to a pair of the quadrants of an electrometer.

If a definite stream of gas is maintained between the two cylinders, then while the potential of the outer tube CC' is above a certain value, all of the ions from the volume dd which move inward will reach DB to the right of the juncture k , and so the electrometer reading will not change. By gradually diminishing the potential of CC' a value is finally reached such that the ions starting from the outer edge d reach DB just to the left of k , as will be indicated by a changing electrometer reading. The value of the voltage A in equation (9) is thus determined, and the value of X , which corresponds to it, is the distance from the beam of rays to the juncture k . In getting X the corrections which must be made for the width of the beam of the rays and for

the width of the juncture k will be considered later. The apparatus as used will now be described.

§ 3. THE APPARATUS.

The main parts of the apparatus are represented in fig. 2, where the lower part of the figure is a vertical section, while the electrical connections in the upper part are viewed from above.

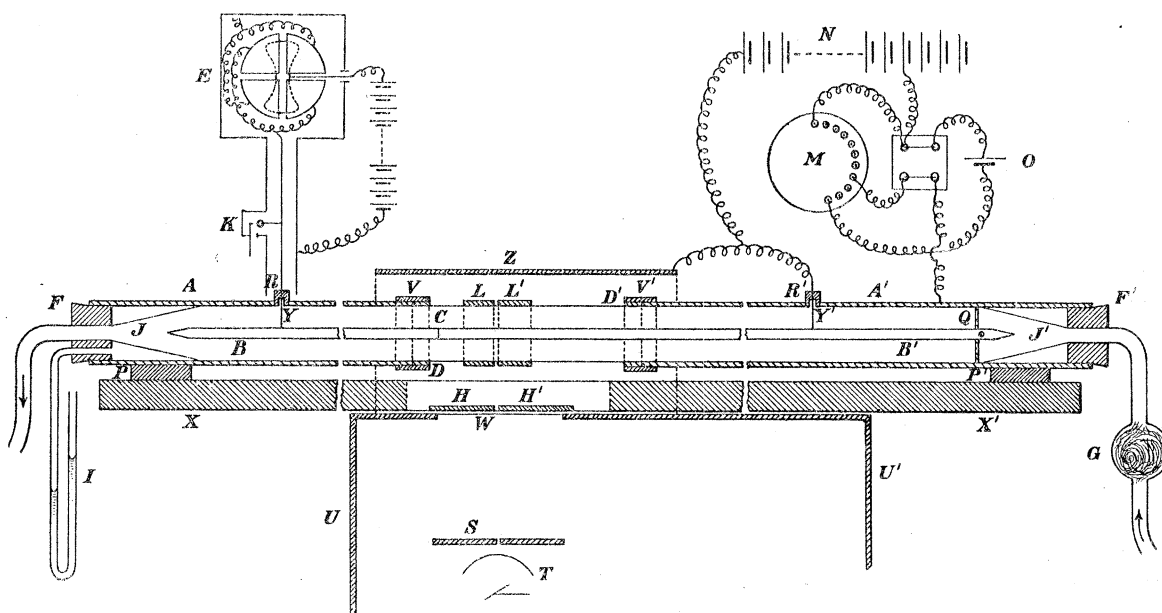

Fig. 2.

The outer cylinder, AA' , had an internal diameter of 5.11 centims., and a total length of 142 centims. For convenience the length is shortened in the figure by the omission of two sections. The part to the left of V , 41 centims. long, and the part to the right of V' , 81 centims. long, were made of strong brass tubing. The portion DD' between these was 20 centims. long, and consisted of an aluminium tube, which was of the same internal diameter as the brass cylinders. Brass collars over the ends of the aluminium tube fitted into the external collars V and V' soldered to the brass cylinders, and so formed close-fitting joints that were made gas-tight by sealing them on the outside. The whole cylinder was supported on a board, XX' , and insulated by means of four paraffin blocks, two of which are represented by P and P' .

The inner cylinder, BB' , was an aluminium tube 1 centim. in diameter, closed at its ends by conical pieces. At C the cylinder was divided so that the two portions were held one-half of a millimetre apart and insulated, by means of an ebonite plug. At the end, B' , the tube was supported and kept central by means of two small ebonite rods, Q . The tube was further supported by the two stiff brass wires, Y and Y' , which lead through the ebonite plugs, R and R' , in the outer cylinder, and served to

make electrical connections. The part B' was joined to earth, while the part B was connected to a pair of the quadrants of the electrometer, E. Great care was taken to adjust the position of the central cylinder so as to be accurately concentric with the outer one.

The ends of the outer cylinder were fitted with the large rubber stoppers F and F'. Through these passed the gas inlet and outlet tubes, whose ends were the elongated funnels J and J'. These funnels, together with the cone endings of the inner cylinder, made the lines of gas motion change less abruptly on entering and leaving the apparatus, and so aided in having the gas maintain a steady motion in DD', where the observations were taken. At the left end, F, a rubber tube led to a gas bag of about 150 litres capacity. The manometer, I, measured the pressure of the gas in the apparatus. The right end, F', was connected to the glass wool chamber, G, which served to remove dust and any stray electrification from the gas. A rubber tube then led to a drying or moistening apparatus, to be described later, which was connected to a large gasometer of the ordinary type. The pressure of the gas in the gasometer was measured by means of a manometer, and a scale was also attached to the gasometer for measuring its rate of descent during an experiment. The average velocity of the gas stream in the apparatus was determined from the volume emitted by the gasometer in a second, and from the area of the cross section between the two cylinders. To prevent the gas in the gasometer from getting moist too rapidly in those cases where dry gases were used, the surface of the water was covered with a layer of oil, such as is used for air pumps, because of its very low vapour pressure.

The board, XX', with the attached cylinders was placed on the top of a lead-covered box, UU', so that DD', the aluminium portion of the outer tube, was above the aluminium window, W, in the box.

The box contained the Crookes' tube and the induction coil for operating it. The form of tube used was that which the writer has previously employed for similar work.* This form was more satisfactory than any of the others tried, and gave the best results when emitting weak rays, and when an interval of rest of at least three or four minutes was allowed between the periods of use, which did not exceed thirty seconds. A 6-inch Apps' coil was used with a hammer interrupter, which could be made to run with sufficient uniformity with an easy running weak ray tube. The source of the rays, T, was more than 20 centims. from the axis of the cylinders.

The narrow vertical beam of rays which was sent up through the cylinders was regulated by adjusting the position of the tube, T, and of the lead plate, S, with its narrow slit, and of the two lead rings, L and L', which fitted over the cylinder, DD'. This adjustment was first made by geometrical arrangement, and then tested and completed with the aid of a fluorescent screen placed over the apparatus. The lead strips, H and H', served to restrict the window, W, and the lead cover, Z, prevented any rays or ionized gas from reaching the outside air of the room.

* J. ZELENY, 'Phil. Mag.,' July, 1898, p. 126.

The quadrant electrometer, E, used for making the measurements was a small bicellular one, the needle of which was suspended by a quartz fibre, and charged through the liquid below by means of a battery of 160 small storage cells. One pair of its quadrants was joined by a wire to the part BC of the inner cylinder. Both the electrometer and the connecting wire were surrounded by an earthed metal case.

The key, K, permitted the insulated quadrants to be connected to earth at any time.

The capacity of the two quadrants and the part of the inner cylinder connected to them, together with the connecting wire, was about 53 centims. The sensibility of the electrometer was about 500 divisions per volt, with the scale at a distance of 130 centims. The potential of the outer cylinder AA' was maintained at any desired value by means of the battery of storage cells, N; the arrangement of the extra cell, O, and the divided megohm, M, permitting the addition of a fractional part of a cell's voltage.

By opening a stop-cock on the gasometer the gas was made to pass from the gasometer, through the apparatus, into the gas bag on the other side, at a rate which was regulated by the weights on the gasometer. It could then be forced back into the gasometer and used again.

A large volume of gas is required for carrying out an experiment, and the method is therefore limited to a small number of gases that can be obtained in such quantities, and that do not act upon the materials of the apparatus.

§ 4. CORRECTIONS AND PRECAUTIONS OBSERVED IN THE EXPERIMENTS.

1. It is essential for these experiments that in its motion down that part of the tube where the observations are being taken, the different portions of the gas should move in paths parallel to the axis of the tube, *i.e.*, that the motion be uniform, and not turbulent with vortices. This condition depends upon the velocity of the gas stream.

O. REYNOLDS has shown* that for motion in a cylindrical tube a fluid when started in a turbulent state will tend to assume a uniform motion with the parts moving parallel to the axis when for the fluid the average velocity is less than a critical value,

$$V = \frac{\mu}{B\rho D},$$

where μ is the viscosity of the fluid relative to that of water at 0° , ρ is its density, D is the diameter of the cylinder, and B is a constant.

The value of B obtained was about 280 when D and V were measured in metres.

Applying this constant to the gases used, for a cylinder of the diameter of the

* O. REYNOLDS, 'Phil. Trans.,' A, 1883.

outer one in the apparatus, we obtain for the value of the critical velocity for air about 55 centims. per second, and for hydrogen about 390 centims. per second. It is evident that in the apparatus used where there are two concentric cylinders, the maximum velocity consistent with a uniform motion must be considerably larger than if the gas were flowing through the outer cylinder alone. Nevertheless the largest value of the velocity used in any experiment was 25 centims. per second for air and 44 centims. per second for hydrogen. As these values are well within the limits given above for a cylindrical tube whose radius is equal to that of the outer one here used, the conditions for a stable motion are fulfilled. The entrance of the gas through a funnel-shaped aperture and its subsequent passage for a considerable distance through a uniform section allowed the motion to come to a permanent state before it reached the place where the observations were taken.

An experiment which was tried showed that by blowing a stream of air down a large glass tube and with a velocity greater than that used in these experiments, the gas assumed a motion parallel to the axis after it had traversed but a short length of the tube, as was made visible by the presence in the air of irregularly distributed ammonium chloride particles.

2. The volume of the gas emitted per second by the gasometer varied a little for different elevations of the gasometer, but there was a considerable range where it was quite constant, and this range only was used in making experiments, the rate of descent being determined in addition during each observation. Guide wheels prevented the tilting of the gasometer during its descent, and the readings on the attached scale could therefore be relied upon. The pressure of the gas was determined by a manometer attached to the gasometer, and the pressure in the apparatus was similarly obtained. The volume of the gas emitted by the gasometer per second was then reduced to the pressure in the apparatus, and dividing by the flow area in the tubes, the required value of U in equation (9) was obtained.

3. In order to understand more clearly the manner in which the values of A and X of equation (9) were determined, let us consider the following case. In fig. 3, CC' represents a longitudinal section of the outer cylinder. DB is the

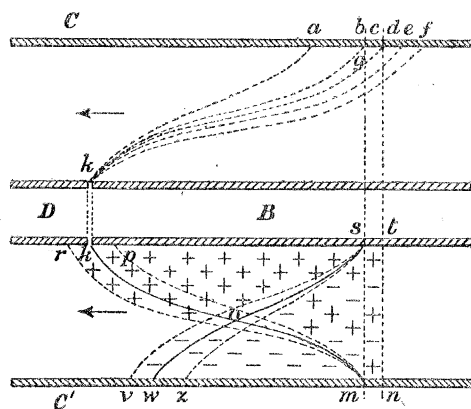

Fig. 3.

inner cylinder having the insulated juncture at k , the part D of the cylinder being connected to an electrometer.

The gas stream is supposed to flow from right to left in the figure, and $bdmn$ is the beam of rays. DB being at zero potential, suppose that when the potential of CC' is at a certain value the ions going towards DB move in paths parallel to the line ak in the upper half of the figure. An ion starting from any point to the left of ak would reach the part D and so influence the electrometer, but as all of the ions start from the beam of rays to the right of ak , all of them reach B. If the potential of CC' is diminished so that the inclination of the ionic paths becomes bk , ions from the outermost rim of $bdmn$ will just begin to reach the part D. By a certain decrement in the potential of CC' the paths of the ions can be made parallel to dk , so that ions will reach D from a volume whose section is represented by the triangle bdg , the width of the beam of rays being bd . By a decrement in the potential of CC' equal to the last one, the volume from which ions reach D is increased by a volume whose section is seen from the figure to be nearly a parallelogram of about twice the area of the triangle bdg . Another equal decrement in the potential increases the volume by almost the same amount as the last. As the potential is diminished further, the rate of increase of volume gradually diminishes. So if we represent the potentials used by abscissas and the volumes from which ions reach D by corresponding ordinates, we obtain a curve, fig. 4,

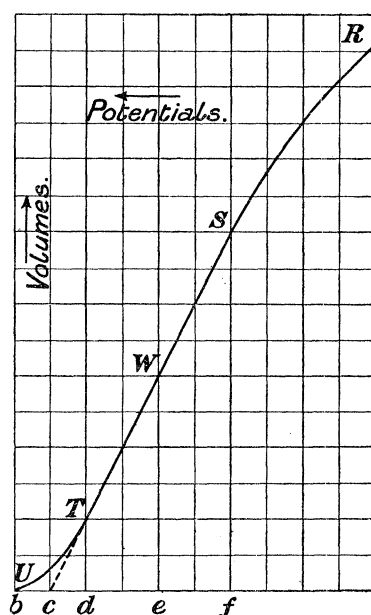

Fig. 4.

whose inclination to the axis of abscissas, as the potentials are increased, at first gradually increases (RS of fig. 4), then assumes a constant value (ST) and finally diminishes (TU) as the curve ends in the axis of abscissas. The point U corre-

sponds to the inclination of the paths of the ions represented by bk of fig. 3, T corresponds to dk , and W to ek . As the paths change from ek to dk , the diminution in the number of ions reaching D is equal to about twice the number that are getting to D in the latter case ($We = 3Td$). If, therefore, the rate of diminution remained unchanged until ions just ceased to reach D, the change in potential required for this would be just a half of the change from ek to dk or from dk to bk . Thus in the curve it is seen that by prolonging WT it reaches the axis at c , half way between b and d . This corresponds to a potential which would be required for an ion starting from c (fig. 3) the middle point of the beam of rays bd , in order to have it just reach the juncture k in the inner cylinder. It is evident that the points T and U are not very sharply defined on an experimental curve, and hence cannot be determined as accurately as the point c , and so in practice the potential A of formula (9) has always been determined in this latter way. Evidently the value of X which is to be used with this value of A has to be measured from the middle of the beam of the rays where they cross the inner cylinder to the middle of the juncture k , as all ions reaching the middle point are drawn to D. The width of this juncture was only .05 centim. The width of the beam of rays was used as small as possible, and in most cases was .2 centim., this being a small part of the total distance X.

4. In considering the distribution of the ions between the two cylinders while the conduction is going on, it is seen from the lower part of fig. 3 that supposing the external tube to be positive, the negative ions starting from s will describe a path somewhat like sw , so that all of the negative ions will be confined to the space $wmnts$. Similarly the positive ions starting from m will describe the path mk , and all of the positive ions will be confined to the space $kmnts$. In the space where these two overlap, *i.e.*, $omnts$, both kinds of ions will be present and recombination will take place, the number of ions per cubic centim. diminishing, therefore, as we go from sm to o .

The space owm will be occupied by negative ions alone, and oks by positive ions alone.

wm will usually be shorter than ks , because as a rule the negative ions travel the faster in the same electric field.

5. Of the ions starting from m towards k all will not follow the path mk , but some, due to the motions assigned to them by the kinetic theory of gases, will diffuse to either side so that the distribution, along the path, of the ions which started from m will lie between the two dotted lines mr and mp . This effect will produce a distortion in such a curve as that shown in fig. 4, and to bring all of the ions to the part B of the inner cylinder will require a greater force than would be necessary if there were no diffusion. The effect of this disturbance upon the value of the ionic velocity obtained in the manner described is to give a result that is too small because the potential A obtained is too large. Moreover the amount of the diffusion depends upon the time required for the ions to travel between the two

cylinders so that if we obtain values of the ionic velocity, in the manner already described, these will be the larger and nearer to the true value the smaller the time that is required for the passage of the ions across.

If this time were zero, then evidently all diffusion effects would disappear.

6. The free charges that exist in the gas, where the ions of one sign predominate, tend to spread on account of the mutual repulsion of the charged carriers.

This produces an effect similar to that of the diffusion just described. It increases with the time required for the ions to pass between the cylinders, but is less the smaller the density of the free charges, *i.e.*, the weaker the Röntgen rays used and the narrower the beam of the rays.

7. The presence of these free charges in the gas also has an influence upon the intensity of the electrostatic field between the two cylinders. To diminish this effect a sensitive electrometer was used in making the observations, as this allowed the employment of a weak radiation so that the charges in the gas were of a small density.

While it is not possible to make an exact calculation of the magnitude of this effect because of the unsymmetrical distribution of the ions, an approximation to it can still be obtained. Knowing the capacity of the receiving system and the charge received in a given time, and knowing the approximate velocity of the ions in the electric field and the approximate space occupied by the free charges, the density of these charges can be obtained roughly, and their effect upon the electrostatic field can be computed.

Computations of this kind made from the observations used for final results showed that the largest value of this correction made a diminution in the electrostatic field of less than 1 per cent. In some experiments where a large inner cylinder was used the intensity of the electric field employed was less, the ions moved slower, and the density of the free charges was therefore larger and in some instances the above correction was perhaps nearly 2 per cent. In all cases an increase in the strength of the field itself diminishes the percentage value of the correction, while the simultaneous diminution in the density of the free charges reduces it still further.

8. The motion of these free charges through the gas also produces a motion of the gas itself, as the writer has previously shown.* The amount of this is, however, very small compared to the velocity of the ions, so that it cannot have an appreciable disturbing effect upon the results of these experiments.

9. In conduction produced by Röntgen rays there is a noticeable fall of potential at the electrodes which diminishes the electric intensity in the intermediate space. As determined by the writer,† for conduction in air between two plates 1·2 centims. apart, this amounted to about 2 per cent. of the total potential difference for the

* J. ZELENY, 'Proc. Camb. Phil. Soc.,' vol. 10, Pt. I., p. 13.

† J. ZELENY, 'Proc. Camb. Phil. Soc.,' vol. 10, Pt. I., p. 21.

strength of rays used. For the much weaker radiation and the greater distance here used the correction does not perhaps exceed 1 per cent. For gases other than air the effect has not been determined, and has been assumed to be no greater than with air.

10. J. PERRIN* has shown that when the Röntgen rays impinge upon a metal surface the ionization in the gas near it is increased by an amount depending upon the nature of the metal and upon the state of its surface. M. G. SAGNAC† and P. LANGEVIN have shown since that this is due to a secondary radiation started at the metal surface by the Röntgen rays. It is possible that the ions so produced are of a different nature from those produced by the direct rays, but in the absence of any evidence to that effect the much more probable case is assumed that the two kinds are identical.

The effect of the secondary rays, therefore, is to produce an uneven distribution of the ions in the space exposed to the direct rays, and also to widen the ionized area near the metal surfaces. This makes more difficult the accurate determination of the potential A in equation (9), the tendency being to get it too large. J. PERRIN found that the surface effect was by far the least for aluminium, what he calls the coefficient being $\cdot 0$ for aluminium in air as compared to $\cdot 9$ for gold in air. The effect is also very much dependent upon the cleanliness of the surface. It is thus seen that in the apparatus used this effect was made as small as possible by using unpolished aluminium as the material for those parts of the cylinders upon which the rays impinged. That the secondary rays did not produce an appreciable amount of ionization at a short distance to the side of the beam of the direct rays was shown by passing these rays near to the insulated juncture in the inner cylinder while the gas in the tubes was at rest. No conductivity was observed to that part of the inner cylinder which was not exposed to the direct rays.

Further experiments tried for the effect of the secondary rays by coating the inside of the aluminium cylinder on the apparatus with tin-foil will be described later among the observations for dry air.

11. W. C. RÖNTGEN‡ has shown that the air itself where it is exposed to the rays acts as a source of a weak secondary radiation. The writer is not aware of any experiments showing any conductivity produced by this radiation, but the experiment referred to in the last section, where a beam of rays near the juncture of the inner cylinder produced no appreciable conductivity on the other side, shows that in these experiments the effect may be disregarded.

12. When D (fig. 3), the part of the inner cylinder joined to the electrometer, takes up a charge in the progress of an observation, the electric field in the vicinity of the juncture becomes slightly distorted, tending to lessen the number of ions

* J. PERRIN, 'Comptes Rendus,' vol. 124, p. 455.

† M. G. SAGNAC, 'Journal de Physique,' 1899, p. 65.

‡ W. C. RÖNTGEN, 'Wied. Ann.,' vol. 64, p. 18.

reaching D. As for each reading this effect starts from zero, the only influence of this upon a series of readings with different potentials is to diminish their values by small amounts nearly proportional to their size, thus having practically no effect upon the result obtained by projecting the curve as in fig. 4.

13. The velocity of the ions is evidently dependent upon the pressure of the gas. In these experiments the variations in the pressure were but small, being due mainly to the variations of the barometer. No experiments have been carried out on the effect of pressure upon the velocity of the ions produced by Röntgen rays, but E. RUTHERFORD* has shown that for the conduction produced by ultra-violet light the velocities of the ions in air are inversely as the pressure of the gas. This result will be used in these experiments to reduce all of the values of the velocities to the same pressure of 76 centims. of mercury.

14. The effect of temperature upon the ionic velocity is not known, so that corrections for temperature could not be made. The temperature was, however, taken in all cases, so that if necessary the correction can be applied later on.

15. In considering the various corrections above, it is seen that the effect of many of them is diminished or made negligible by using a narrow beam of weak rays, and by using unpolished aluminium for that part of the cylinders where the rays impinge. Those corrections which depend upon the time required for the ions to cross between the two cylinders could be made very small by sufficiently reducing the value of this time, but we are limited in doing so by the increase that is produced in the difficulty of measuring one of the required quantities. Resort must be had to finding the values of the ionic velocities for different times of crossing, and from these deriving the final results.

An estimated correction of 2 per cent. will be made for those effects considered above, especially (7) and (9), which tend to make the result too small by an undetermined but small amount.

§ 5. CHANGES MADE IN EXPERIMENTAL CONDITIONS.

The apparatus used permits of several changes in the experimental conditions, which are a test of the accuracy of the method, and allow us to draw conclusions about the effects of some of the corrections previously noted.

1. The velocity of the gas stream was varied by changing the weights on the gasometer. This necessitated a proportionate change in the value of the potential A of equation (9). The paths described by the ions are the same, but the time required for their passage between the two cylinders is changed. There are also changes in the amount of recombination of the ions and in the diffusion effect. The density of the free charges is changed, and so their effect upon the electric intensity is altered, and the spreading due to the mutual repulsion of the ions is also different.

* E. RUTHERFORD, 'Proc. Camb. Phil. Soc.,' vol. 9, Pt. VIII., p. 414.

2. The distance of the beam of rays from the insulated juncture in the inner cylinder was also changed. This likewise necessitated a change in the value of the potential A , but in the opposite sense. The paths of the ions are now quite different, and changes are also produced in all of the quantities mentioned in the preceding case.

3. The intensity of the Röntgen rays was also varied. This produced alterations in the density of the free charges in the gas, and consequently in their effect upon the electric field between the cylinders and in the mutual repulsion of the ions. The amount of the recombination of the ions is also affected as well as the fall of potential at the electrodes.

4. By changing the diameter of the internal cylinder complete changes are produced in the configuration of the forces, and of the motions of the ions. All the other changes can also be tried in conjunction with this one.

5. The material of the inner surface of the outer cylinder was also altered to note the influence upon the result of increased ionization at the metal surface.

6. In trying to find the effect of any of these changes upon the observed velocity the greatest difficulty met with is due to the smallness of the effects, and their consequent masking by the irregularities of individual observations caused by the difficulty of maintaining a uniform radiation for a length of time sufficient to cover a number of readings. Individual observations taken under the same conditions may vary among themselves by a number of per cent., so a small change in the result cannot be detected unless a large number of observations is made.

§ 6. METHOD OF CONDUCTING THE EXPERIMENTS.

The following procedure was followed in taking readings with the apparatus. The Crookes' tube and the lead slits were accurately adjusted, so that the beam of rays occupied the desired position, and the distance X of equation (9) was carefully measured. The cylinder AA' was connected to a chosen potential on the battery N . The electrometer quadrants, joined to the part B of the inner cylinder, were then disconnected from earth by means of the key K , and the zero reading was observed on the scale. The reading on the gasometer scale was also taken. At a definite time, observed on a chronometer, the valve at the gasometer was opened, so that the gas began to flow through the apparatus. After a short period, usually 10 seconds, sufficient to produce a steady state of flow in the apparatus, the primary of the induction coil was closed and the rays thus started. The rays were allowed to run for 30 seconds, and the primary of the coil was then broken, and the valve of the gasometer was also closed at a definite time. The electrometer reading was now taken, and the deflection produced was obtained. The key K was then closed, and the quadrants of the electrometer were connected to earth. From the reading on

the gasometer scale the volume emitted was obtained, and with the aid of the pressure readings which were taken the average velocity of the gas stream in the apparatus could be calculated.

An interval of about three minutes was allowed as a rest for the tube, as this made it much more constant over a large number of readings. In the mean time, if necessary, gas was forced back from the gas bag into the gasometer. Guided by the previous electrometer deflection the potential of the outer cylinder was now changed, and the whole process repeated. In this way a number of readings were taken, such that the electrometer deflections ranged from some value down to near zero. These were taken in such an order that at first, say, a descending series of readings was obtained, and then immediately afterwards an ascending series. In this manner it is possible to detect any uniform changes which are taking place in the intensity of the rays, for in that case the two series of points would lie on curves of different inclinations.

It was seen in § 5 that the time of passage of the ions from one cylinder to the other could be varied by changing the velocity of the gas stream, and also by changing the distance X . Both of these were employed in practice, and it was found that the values of the velocity obtained diminished as the time increased; but they were practically the same for two different values of X if the velocity of the gas stream was changed in the same ratio, *i.e.*, if the time of passage of the ions was the same.

J. S. TOWNSEND* has recently observed that the rate of diffusion of the ions depends upon the moisture in the gas. In these experiments the gases were used both dry and saturated with aqueous vapour, and it was found that the velocity was different in the two cases.

For saturating a gas with aqueous vapour it was forced, in passing between the gasometer and the apparatus, to bubble through a water bottle and then to pass through a long horizontal tube half filled with water. After the gas had been passed several times back and forth between the gasometer and the gas bag, and before any readings were taken, the water bottle was cut out so as to avoid any unsteadiness in the pressure due to the bubbling.

For drying a gas the above arrangement was replaced by one in which the gas had to pass through a long, horizontal glass tube, partly filled with concentrated sulphuric acid, and then through a large volume of calcium chloride. In order to allow a sufficiently rapid stream with the small pressures used the calcium chloride was placed in a large, wide bottle, the gas entering above and leaving by a protected funnel-shaped tube near the bottom. It thus had to traverse a considerable length of calcium chloride, and on account of the large area of the bottle the velocity through it was small.

* J. S. TOWNSEND, 'Phil. Trans.,' A, vol. 193.

§ 7. MOIST AIR.

The following is an example of a set of readings taken for the positive ions in air saturated with aqueous vapour.

Letters refer to corresponding quantities in formula (9).

Temperature = 14.5° C. $X = 2.60$ centims. $a = .50$ centims. $b = 2.555$ centims.

Width of beam of rays = $.20$ centim. Barometer = 75.4 centims.

Excess pressure inside gasometer = 1.56 centims. of mercury.

„ „ in apparatus = $.59$ centim. of mercury.

20 cells = 42.6 volts.

TABLE I.—Moist Air. Positive Ions.

Voltage of outer cylinder.	Electrometer deflection in 30 seconds.	Descent of gasometer in 40 seconds.
Cells.	Divisions.	Centims.
+10	145	6.77
+12	105.5	6.79
+14	68.5	6.78
+16	29.5	6.72
+18	12	6.70
—	—	—
+19	7	6.83
+17	19	6.81
+15	52.5	6.78
+13	87	6.77
+11	128	6.76

In the middle of the observations the gasometer was refilled from the gas bag. The sectional area of the gasometer was 2904 sq. centims., and the area between the two cylinders was 19.73 sq. centims., so the average rate of descent of the gasometer above indicates an average velocity in the apparatus of 25.2 centims. per second, when corrected for the difference in pressure between the gasometer and the apparatus.

The voltages and their corresponding deflections are represented graphically in curve I. of fig. 5. The set of readings here given, and most of those which are to follow as examples, have been selected from among the best obtained.

It is seen that the curve at first approaches the axis of abscissas in nearly a straight line, but becomes convex when near to it. Had readings been taken for voltages smaller than those used, that part of the curve would have been concave to the axis of abscissas.

It has been explained in § 4 (3), why there is a nearly straight portion in the curve, while the width of the beam of rays and the various causes tending to spread

the ions make the lower end of the curve approach the axis at a less rapid rate. It was also shown that the point on the axis of abscissas, obtained by prolonging the straight portion of the curve, would correspond to the voltage required to make an

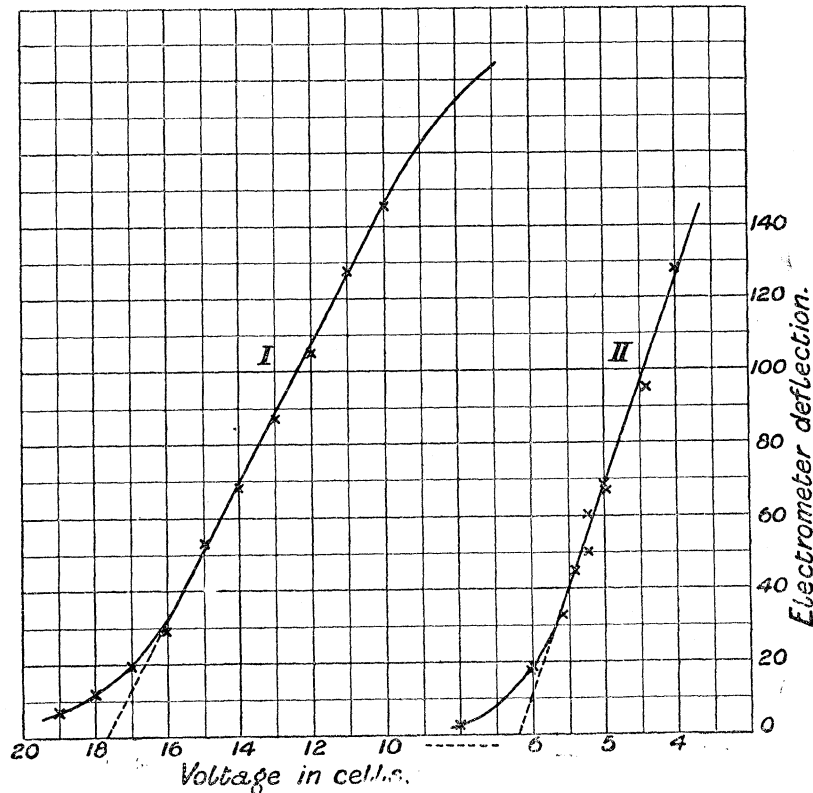

Fig. 5.

ion, starting from the surface of the outer cylinder in the middle of the beam of rays, just reach the middle of the juncture in the inner cylinder. But with diffusion and the other causes acting to produce a spreading of the ions, it is evident that the inclination of the straight part itself is affected and the result changed. Corrections for this error can only be made in conjunction with those of some other effects, and that by experiment, by producing alterations in the amount of these effects, by changes in the time of passage of the ions across the space between the cylinders.

The velocity obtained by the use of the voltage determined by the continuation of the straight part of the curve, as shown in the figure, will be called the ionic velocity for that determination, it being understood that it is not implied thereby that the velocity changes with the time, but that this is only a step towards the final result. From the above curve, A is seen to be 17.7 cells, which is equal to 37.7 volts.

Using equation (9),

$$v = \left\{ \frac{b^2 - a^2}{2} \log_e \frac{b}{a} \right\} \frac{U}{AX} = 5.118 \frac{25.2}{2.60 \times 37.7} = 1.315 \text{ centims. per second.}$$

The pressure in the apparatus is 76 centims. of mercury

From equation (10)

$$T = \frac{X}{U} = \frac{2.6}{25.2} = .10 \text{ second.}$$

The following is a set of readings taken for negative ions in moist air. Unless otherwise mentioned the values of a , b , and the width of the beam of rays will hereafter be taken the same as in the previous example.

Temperature = 14.4° C. $X = 6.42$ centims. Barometer = 74.7 centims.

Excess pressure inside gasometer = 1.54 centims. of mercury.

„ „ in apparatus = .59 centim. of mercury.

8 cells = 16.5 volts.

TABLE II.—Moist Air. Negative Ions.

Voltage of outer cylinder.	Electrometer deflection in 30 seconds.	Descent of gasometer in 40 seconds.
Cells.	Divisions.	Centims.
- 4	128	6.05
- 5	68.5	5.95
- 5.4	45	5.94
- 6	17.5	5.92
- 5.6	32.5	5.89
- 5.2	50	5.90
- 6	18	6.02
- 5.4	44.5	5.99
- 5	67.5	5.96
- 4.4	95	5.90
- 7.	2	5.90

The results are represented in Curve II. of fig. 5.

$U = 22.1$ centims. per second.

$A = 12.7$ volts.

$v = 5.118 \frac{22.1}{6.42 \times 12.7} = 1.39$ centims. per second.

The pressure in the apparatus = 75.3 centims.

The velocity reduced to 76 centims. pressure = 1.38 centims. per second.

$T = \frac{6.42}{22.1} = .29$ second.

The following is a summary of the results obtained for moist air for both the positive and negative ions. Each result was obtained from a series of observations as indicated by the above examples. The results are reduced to 76 centims. pressure.

Letters refer to quantities in equations (9) and (10).

TABLE III.—Moist Air. Summary of Results.

Reference number.	X.	U.	A.	T.	Temperature.	Gas pressure.	Ionic velocity.	
							Negative.	Positive.
					° C.			
1	4.33	20.6	+19.2	.21	15.3	76.2	—	1.28
2	4.18	10.85	+11.1	.39	15	77.6	—	1.225
3	4.18	11.1	-10.1	.38	15	77.6	1.37	—
4	4.18	10.73	-9.8	.39	14.3	76.5	1.35	—
5	4.18	10.96	+11.35	.38	14.3	76.5	—	1.19
6	4.18	25.0	+23.4	.17	14.3	76.8	—	1.32
7	4.18	25.0	-21.2	.17	14.3	76.8	1.46	—
8	2.68	11.3	-15.65	.24	14.6	75.9	1.38	—
9	2.68	11.3	+17.5	.24	14.6	75.9	—	1.23
10	2.68	22.0	+32.15	.12	14	76.1	—	1.32
11	2.68	22.1	-29.1	.12	14	76.1	1.46	—
12	8.41	11.33	+6.26	.75	14.4	76.0	—	1.10
13	8.41	11.23	+6.03	.75	14.4	76.0	—	1.13
14	8.41	10.78	-5.2	.78	14.4	76.0	1.26	—
15	8.41	11.33	-5.41	.74	14.4	76.0	1.27	—
16	8.41	11.8	-5.51	.72	14.4	76.0	1.30	—
17	8.41	24.8	-10.95	.34	14.2	76.2	1.39	—
18	8.41	24.73	+12.2	.34	14.2	76.2	—	1.24
19	8.41	24.8	+12.5	.34	14.2	76.2	—	1.22
20	8.41	24.8	-10.7	.34	14.2	76.2	1.42	—
21	6.42	10.67	-6.57	.60	13.5	75.8	1.30	—
22	6.42	10.7	+7.26	.60	13.5	75.8	—	1.175
23	6.42	22.06	+14.0	.29	14.4	74.8	—	1.245
24	6.42	22.06	+14.15	.29	14.4	74.8	—	1.23
25	6.42	22.1	-12.7	.29	14.4	74.7	1.38	—
26	2.60	11.1	-15.7	.29	14.7	74.7	1.375	—
27	2.60	11.1	+17.0	.24	14.7	74.7	—	1.27
28	2.60	25.2	+37.7	.10	14.5	75.4	—	1.315
29	2.60	25.2	-34.1	.10	14.5	75.4	1.455	—
30	2.60	12.6	-17.8	.21	15	75.5	1.39	—
31	2.60	10.9	-15.7	.24	15	75.5	1.37	—
32	2.60	13.1	-18.3	.20	16	75.7	1.41	—
33	2.60	13.15	-17.8	.20	16	75.7	1.45	—

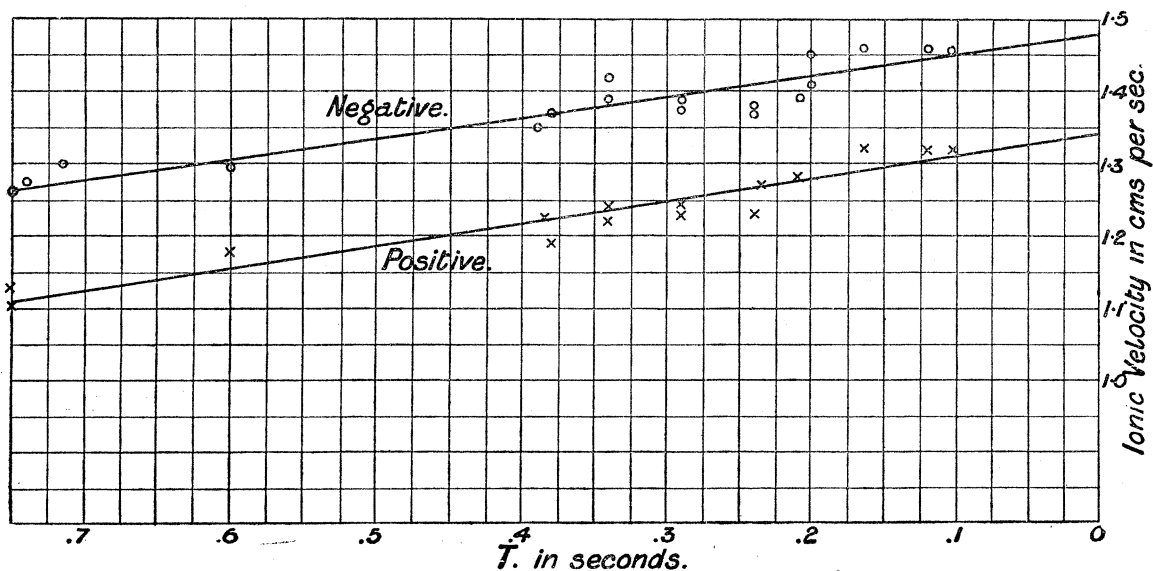

Fig. 6.

The results are represented in fig. 6, where the velocities are represented as ordinates and the corresponding values of T as abscissas. It is seen that the velocities decrease with T , and nearly in a linear manner. Considerable variations are observed among the individual results, but it is believed that they are not greater than is to be expected from the nature and difficulties of the experiments.

In § 4 it was seen that some of the corrections which act to give too small a value for the velocity diminish with T and disappear for $T = 0$. By drawing lines through the points in fig. 6 and prolonging them to the axis of ordinates where $T = 0$, we obtain the most probable values of the velocities. This gives for the negative ions 1.48 centims. per second, and for the positive ions 1.34 centims. per second.

In § 4 (15) it was stated that a correction of 2 per cent. would be made for disturbances not corrected by the above method. This gives for the final results for moist air the velocity in an electric field of 1 volt per centim. for the negative ions = 1.51 centims. per second, and for the positive ions = 1.37 centims. per second at a temperature of about 14° C., and a pressure of 76 centims. of mercury.

§ 8. DRY AIR.

The following set of readings was taken for the positive ions in dry air :—

Temperature = 13.8° C. $X = 2.60$ centims. Barometer = 76.1 centims.

Excess pressure in gasometer = 1.6 centims. of mercury.

” ” apparatus = .45 ” ”

14 cells = 29.0 volts.

TABLE IV.—Dry Air. Positive Ions.

Voltage of outer cylinder.	Electrometer deflection in 30 seconds.	Descent of gasometer in 40 seconds.
Cells.	Divisions	Centims.
+ 8	117	4.29
+ 10	60	4.28
+ 12	22	4.26
+ 14	7	4.26
+ 11	40	4.22
+ 9	94	4.25
+ 7	153	4.25
+ 10	62	4.21
+ 8	123	4.23

These results are represented graphically in Curve I. of fig. 7.

The corrected value of U is 15.9 centims. per second.

$A = 24.8$ volts.

So $v = 5.118 \frac{15.9}{2.60 \times 24.8} = 1.26$ centims. per second, and when reduced to

76 centims. pressure this becomes 1.27 centims. per second.

$T = \frac{2.60}{15.9} = .16$ second.

The following set of readings was taken for the negative ions in dry air :—

Temperature = 15.8° C. $X = 2.60$ centims. Barometer = 76 centims.

Excess pressure in gasometer = 1.0 centim.

„ „ „ apparatus = .13 centim.

7 cells = 14.5 volts.

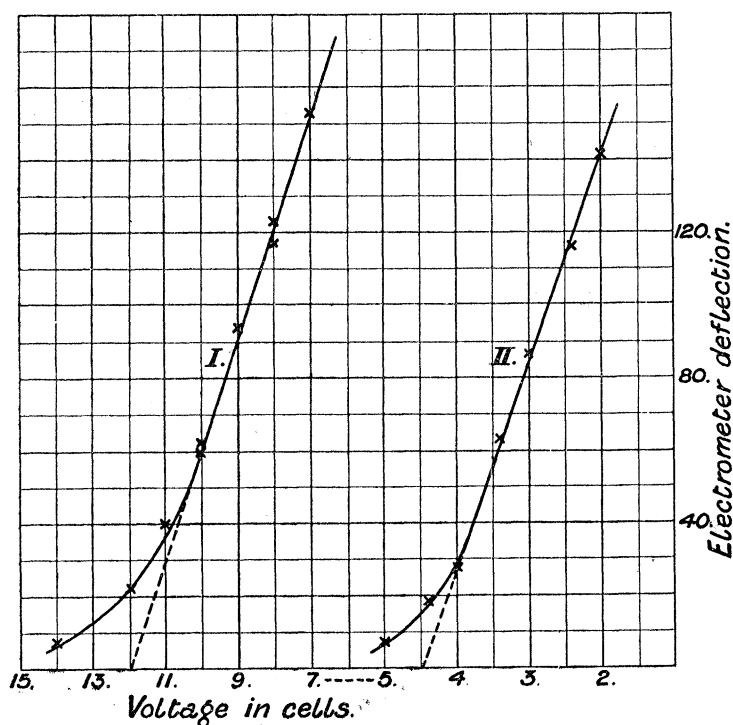

Fig. 7.

TABLE V.—Dry Air. Negative Ions.

Voltage of outer cylinder.	Electrometer deflection in 30 seconds.	Descent of gasometer in 40 seconds.
Cells.	Divisions.	Centims.
- 2	141.5	2.07
- 3	87	2.05
- 4	28.5	2.08
- 5	6.5	2.05
- 4.4	18	2.08
- 3.4	63	2.05
- 2.4	116	2.05

The results are shown graphically in Curve II. of fig. 7.

U corrected for pressure = 7.64 centims. per second.

$A = 9.21$ volts.

$$v = 5.118 \frac{7.64}{2.60 \times 9.21} = 1.63 \text{ centims. per second.}$$

$$T = - \frac{2.60}{7.64} = .34 \text{ second.}$$

A summary of the results obtained for dry air for both the positive and the negative ions is given in Table VI.

TABLE VI.—Dry Air. Summary of Results.

Reference number.	X.	U.	A.	T.	Temperature.	Gas pressure.	Ionic velocity.	
							Negative.	Positive.
					° C.			
1	2.60	7.64	- 9.21	.34	15.8	76.2	1.63	—
2	2.60	7.64	+ 12.0	.34	15.8	76.2	—	1.25
3	2.60	7.64	+ 12.2	.34	16.3	75.8	—	1.23
4	2.60	7.57	- 9.31	.34	16.3	75.8	1.60	—
5	2.60	7.28	- 9.15	.36	12.2	76.6	1.58	—
6	2.60	7.23	+ 12.15	.36	12.2	76.6	—	1.18
7	2.60	15.8	- 18.3	.16	13.8	76.6	1.71	—
8	2.60	15.9	+ 24.8	.16	13.8	76.6	—	1.27
9	2.60	15.9	- 18.1	.16	13.8	76.6	1.74	—
10	2.60	15.9	- 18.3	.16	13.8	76.6	1.725	—
11	2.60	16.6	- 18.65	.16	14.6	75.8	1.75	—
12	2.60	16.3	- 18.22	.16	14	76.8	1.78	—
13	2.60	15.5	+ 24.8	.17	12.5	76.7	—	1.25
14	2.60	15.5	+ 23.7	.17	10.7	77.6	—	1.31
15	2.60	15.6	- 18.1	.17	10.7	77.6	1.72	—
16	5.15	8.65	+ 7.76	.60	11.4	77.3	—	1.13
17	5.15	8.62	- 5.9	.60	11.4	77.3	1.47	—
18	5.15	15.6	- 9.31	.33	11.4	77.6	1.67	—
19	5.15	15.7	+ 12.6	.33	11.4	77.6	—	1.26
20	5.15	8.58	+ 7.64	.60	11.7	77.5	—	1.14
21	5.15	8.58	- 5.88	.60	11.7	77.5	1.48	—

At No. 7 the drying apparatus was changed, and at No. 12 the Crookes' tube was replaced by a new one.

The results are represented in fig. 8, excluding the points marked by squares.

The final values thus obtained for dry air when the 2 per cent. correction mentioned in § 4 (15) has been added, give the velocity of the negative ions = 1.87 centims. per second, and of the positive ions = 1.36 centims. per second.

The temperature varied several degrees between the different observations, but was on the average about 13° C.

Most of the tests to which the method used in these experiments was subjected by changes of experimental conditions, were tried with dry air. Among these was tried the effect of changes in the intensity of the rays. By interposing aluminium plates the rays were diminished so that the conductivities produced by them changed

in the ratio of three to one, but no noticeable change in the result could be observed. During the course of all of the experiments the rays were not of the same intensity, for the Crookes' tube had to be replaced several times, but in all cases without any marked effect upon the values obtained. It must be said, however, that rays of great intensity were never employed, the aim being always to have them as weak as possible for reasons previously stated.

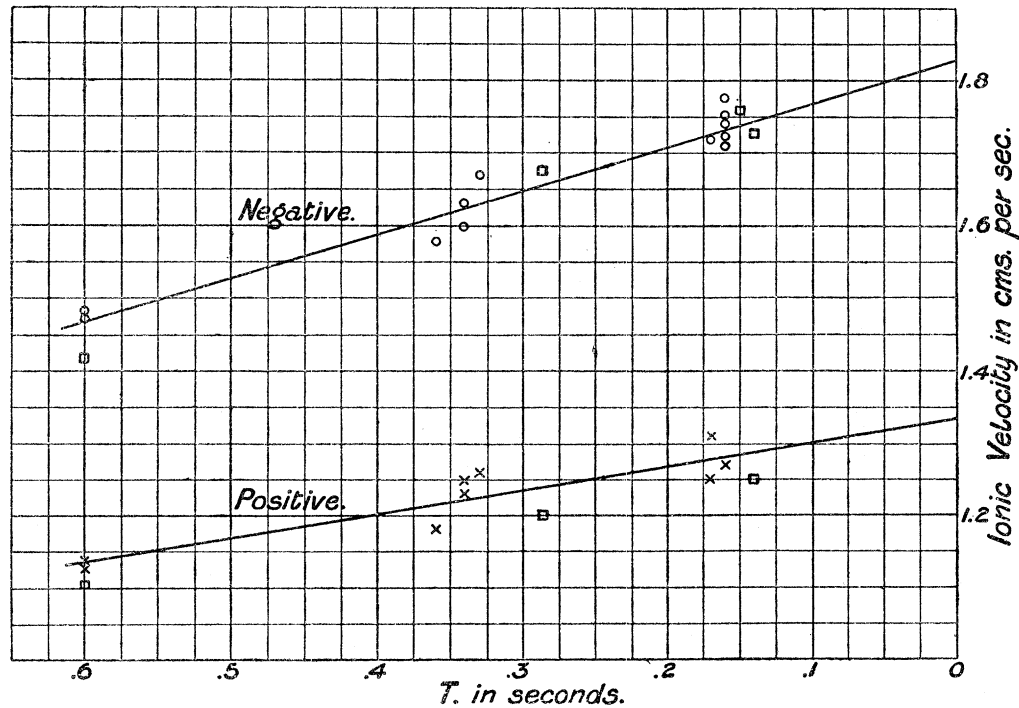

Fig. 8.

The most severe test to which the method was subjected was a change in the dimensions of the inner cylinder. In the above experiments the diameter of this cylinder was 1 centim., and it was now exchanged for one having a diameter of 2.8 centims. The distance between the inner and the outer cylinders was thus diminished to nearly one-half of its former value. The electric field between the two became much more uniform, and the gas velocities for different points of a cross-section now varied in a different manner. In order to keep the other quantities the same, the small distance between the two cylinders necessitated the use of voltages only about one-quarter as large as those used in the former arrangement. This increased the difficulty of the measurements and also some of the corrections which must be applied to get the final result. The density of the free charges in the gas was greater because the ions moved slower, being in a weaker field, and the same fall of potential at the electrodes was a larger percentage of the total voltage. The width of the beam of rays used was .3 centim.

The following is a summary of the results obtained :—

TABLE VII.—Dry Air. Summary for Large Inner Cylinder.

Reference number.	X.	U.	A.	T.	Temperature.	Gas pressure.	Ionic velocity.	
							Negative.	Positive.
1	5.4	10.7	-1.90	.50	°C. 11.8	75.9	1.43	—
2	5.4	12.6	-2.23	.43	12.4	75.9	1.43	—
3	5.4	12.7	+2.84	.43	12.4	75.9	—	1.13
4	5.4	10.4	+2.35	.52	12.4	75.9	—	1.10
5	3.77	11.55	+3.75	.33	15	75.8	—	1.12
6	3.77	11.55	-2.70	.33	15	75.8	1.555	—
7	3.77	11.65	-2.80	.33	15	75.8	1.51	—
8	5.11	13.9	-2.64	.37	15.4	76.8	1.43	—
9	5.11	13.95	+3.39	.37	15.4	76.8	—	1.115
10	3.26	13.8	-4.06	.24	15.4	76.8	1.57	—
11	6.35	8.83	-1.48	.72	16	77.2	1.315	—
12	6.35	8.83	+1.80	.72	16	77.2	—	1.08
13	6.35	14.05	+2.80	.45	15.8	76.0	—	1.09
14	6.35	14.2	-2.20	.45	15.8	76.0	1.40	—
15	2.63	14.9	-4.7	.18	15.8	76.0	1.65	—
16	2.63	7.7	+3.5	.34	16.3	75.9	—	1.14
17	2.63	7.04	-2.5	.37	16.3	75.9	1.465	—
18	2.63	13.9	-4.32	.19	16.3	75.9	1.67	—
19	2.63	14.06	+5.94	.19	16.3	75.9	—	1.23

The results are represented in fig. 9.

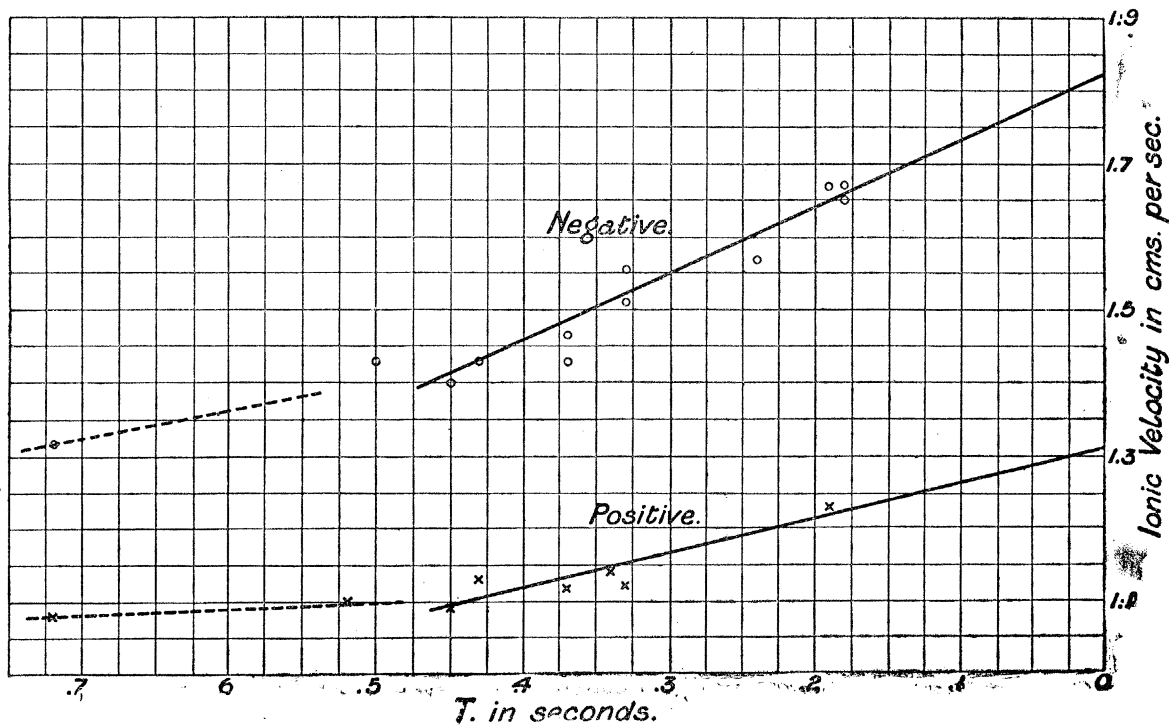

Fig. 9.

It is seen that in this case the values of the velocity change less rapidly as the values of T become large; but for the smaller values of T the change is more rapid than it was when the smaller inner cylinder was used. The points on the curves are not advantageously distributed, and so do not allow of a very accurate projection of the lines to $T = 0$; but from those drawn it is seen that the results are but slightly smaller than those obtained with the smaller inner cylinder. This is considered a good agreement even if it is left out of account that an additive correction is still to be made.

An alteration which was tried to test the effect of surface ionization was a change in the material of the inner surface of the outer cylinder. The aluminium part DD' (fig. 2) of the outer cylinder was coated on its inner surface with a layer of tin-foil. The rays in penetrating the cylinder now had a tin instead of an aluminium surface in contact with the air. J. PERRIN has shown (see § 4 (10)) that what he calls the coefficient of the increased ionization at a metal surface is for tin in air $\cdot 6$ as against $\cdot 0$ for aluminium in air. The effect varies with the state of the surface. In these experiments the aluminium surface used was an ordinary unpolished surface, while the tin surface used was that of bright tin-foil. It was thought that if an increase of the ionization near the metal surface has any marked effect upon the value of the velocity obtained, the difference should be observed by this new arrangement.

The results obtained are given in Table VIII., dry air being used as before. The smaller inner cylinder having a diameter of 1 centim. was used.

TABLE VIII.—Dry Air. Summary for Tin Surface.

Reference number.	X.	U.	A.	T.	Temperature.	Gas pressure.	Ionic velocity.	
							Negative.	Positive.
					° C.			
1	5·22	8·56	− 6·06	·6	13·9	77·3	1·42	—
2	5·22	8·61	+ 7·82	·6	13·9	77·3	—	1·105
3	5·22	18·2	+ 15·2	·29	14·4	77·4	—	1·20
4	5·22	18·2	− 10·8	·29	14·4	77·4	1·68	—
5	2·62	17·3	− 19·6	·15	?	77·2	1·76	—
6	2·62	18·5	− 21·2	·14	16·5	77·2	1·73	—
7	2·62	18·5	+ 29·4	·14	16·5	77·2	—	1·25

The points are plotted as squares on the curves in fig. 8, which represent corresponding values when the aluminium surface was used. It is seen that the points for the negative ions agree very well with the curve. The points for the positive ions are 2 to 3 per cent. below the values for the aluminium surface. Taking both results into consideration it was concluded, if the addition of a tin surface changed the values of the velocities by but such a small amount, that originally when the

aluminium surface was used, the effect of the surface ionization could not have been sufficient to produce any marked error in the results.

The surface ionization also varies with the nature of the gas, but the values obtained by J. PERRIN for aluminium with the gases used in these experiments were in all cases much less than for tin in air.

§ 9. OXYGEN.

The gas used in these experiments was the commercial oxygen obtained from a cylinder, which contained about 5 per cent. of impurities, mostly nitrogen. Since the size and nature of the apparatus prevented the employment of the most pure gases, it seemed advisable to use the cylinder gas. The density was changed but little by the presence of the impurities, and, so far as known, the velocity should therefore be but slightly affected. The drying of the gas and its saturation with aqueous vapour were carried out in the same manner as with air. The following set of readings was taken for the negative ions in oxygen saturated with aqueous vapour:—

Temperature = 17·3° C. X = 5·01 centims. Barometer = 76·4 centims.
 Excess pressure in gasometer = 1·54 centims.
 „ „ apparatus = ·55 centim.
 8 cells = 16·3 volts.

TABLE IX.—Moist Oxygen. Negative Ions.

Voltage of outer cylinder.	Electrometer deflection in 30 seconds.	Descent of gasometer in 40 seconds.
Cells.	Divisions.	Centims.
— 3	194·5	5·06
— 4	157	5·11
— 5	106·5	5·02
— 6	41	5·11
— 6·6	17	5·07
— 5·6	67	5·08
— 5·2	93·5	5·09
— 4·6	125·5	5·03

The results are shown in Curve I. of fig. 10.

The corrected value of $U = 18·83$ centims. per second.

$$A = 13·55 \text{ volts.}$$

$$v = 5·118 \frac{18·83}{5·01 \times 13·55} = 1·413 \text{ centims. per second, and when reduced to } 76 \text{ centims. pressure this becomes } 1·43 \text{ centims. per second.}$$

$$T = \frac{5·01}{18·83} = ·27 \text{ second.}$$

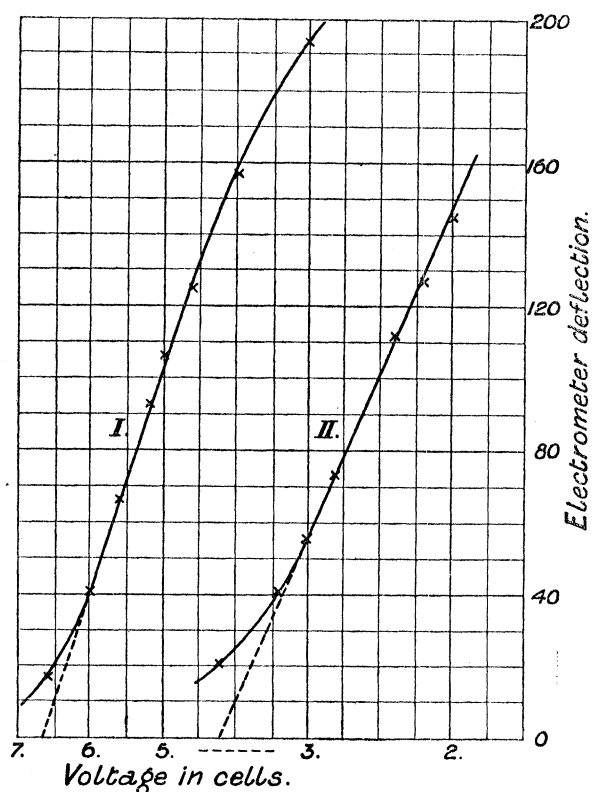

Fig. 10.

The following is a set of readings taken for the positive ions in oxygen saturated with aqueous vapour :—

Temperature = 15.6° C. $X = 5.01$ centims. Barometer = 76.5 centims.

Excess pressure in gasometer = $.44$ centims.

„ „ apparatus = $.16$ „

6 cells = 12.35 volts.

TABLE X.—Moist Oxygen. Positive Ions.

Voltage of outer cylinder.	Electrometer deflection in 30 seconds.	Descent of gasometer in 40 seconds.
Cells.	Divisions.	Centims.
+ 2	145	2.30
+ 3	55.5	2.31
+ 3.6	20.5	2.29
+ 3.2	41	2.29
+ 2.8	73.5	2.27
+ 2.4	112	2.25
+ 2.2	127	2.25

The results are represented by Curve II. of fig. 10.

The corrected value of $U = 8.42$ centims. per second.

$$A = 7.42 \text{ volts.}$$

$$v = 5.118 \frac{8.42}{5.01 \times 7.42} = 1.16 \text{ centims. per second, and when reduced to } 76 \text{ centims. pressure this becomes } 1.17 \text{ centims. per second.}$$

$$T = \frac{5.01}{8.42} = .6 \text{ second.}$$

A summary of the results thus obtained for moist oxygen for both the positive and the negative ions is given in Table XI.

TABLE XI.—Moist Oxygen. Summary of Results.

Reference number.	X.	U.	A.	T.	Temperature.	Gas pressure.	Ionic velocity.	
							Negative.	Positive.
					°C.			
1	6.89	9.41	+ 6.04	.73	15.4	76.8	—	1.17
2	6.89	9.38	— 5.38	.73	15.4	76.8	1.31	—
3	6.89	16.8	— 8.80	.41	15.5	77.3	1.44	—
4	6.89	16.8	+ 10.5	.41	15.5	77.3	—	1.21
5	5.01	8.42	+ 7.42	.6	15.6	76.7	—	1.17
6	5.01	8.68	— 6.69	.58	15.6	76.7	1.34	—
7	5.01	18.8	— 13.55	.27	17.3	76.9	1.43	—
8	5.01	18.6	+ 15.7	.27	17.3	76.9	—	1.23
9	3.03	20.5	+ 27.3	.15	15.4	76.9	—	1.29
10	3.03	20.6	— 24.25	.15	15.4	76.9	1.46	—

The results are shown graphically in fig. 11.

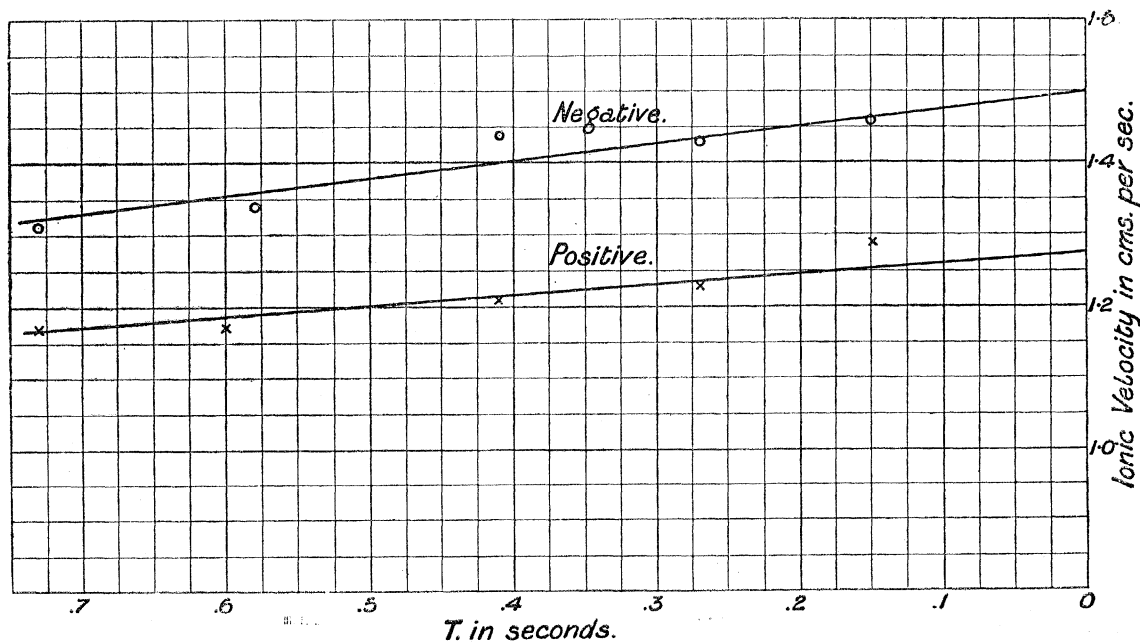

Fig. 11.

The correction mentioned in § 4 (15), which is to be applied to the values indicated at $T = 0$ has in this case been reduced to 1 per cent., 1 per cent. being allowed for an increase in the velocity due to a diminution of density caused by the impurities in the gas. The corrected value thus obtained for the velocity in moist oxygen is for the negative ions = 1.52 centims. per second, and for the positive ions = 1.29 centims. per second, at a pressure of 76 centims. and at a temperature of about 16° C.

The following is a summary of the results obtained for the positive and negative ions in dry oxygen :—

TABLE XII.—Dry Oxygen. Summary of Results.

Reference number.	X.	U.	A.	T.	Temperature.	Gas pressure.	Ionic velocity.	
							Negative.	Positive.
1	2.73	13.9	+20.2	.20	$^{\circ}$ C. 20.3	77.3	—	1.31
2	2.73	13.8	-15.37	.20	20.3	77.3	1.71	—
3	2.73	13.3	+19.5	.21	19.4	77.4	—	1.31
4	2.73	13.3	-14.7	.21	19.4	77.4	1.72	—
5	2.73	13.3	+19.5	.21	19.4	77.4	—	1.30
6	3.89	16.65	-13.6	.23	15	78	1.66	—
7	3.89	17.7	+17.7	.22	15.6	78	—	1.35
8	3.89	16.9	-13.4	.23	15.6	78	1.71	—
9	3.89	7.97	-6.82	.49	16	76.8	1.56	—
10	3.89	8.46	+9.45	.46	16	76.8	—	1.19
11	6.89	8.92	+5.64	.77	15.2	77.1	—	1.19
12	6.89	9.07	-4.53	.76	15.2	77.1	1.51	—
13	6.89	17.35	-8.05	.40	15.8	77.1	1.63	—
14	6.89	17.4	+10.33	.40	15.8	77.1	—	1.27

The results are represented graphically in fig. 12.

When, as in the case of moist oxygen, a 1 per cent. additive correction is applied to the values indicated in the figure by $T = 0$, the final result for the velocity in dry oxygen is for the negative ions = 1.80 centims. per second, and for the positive ions = 1.36 centims. per second for a pressure of 76 centims. and a temperature of about 17° C.

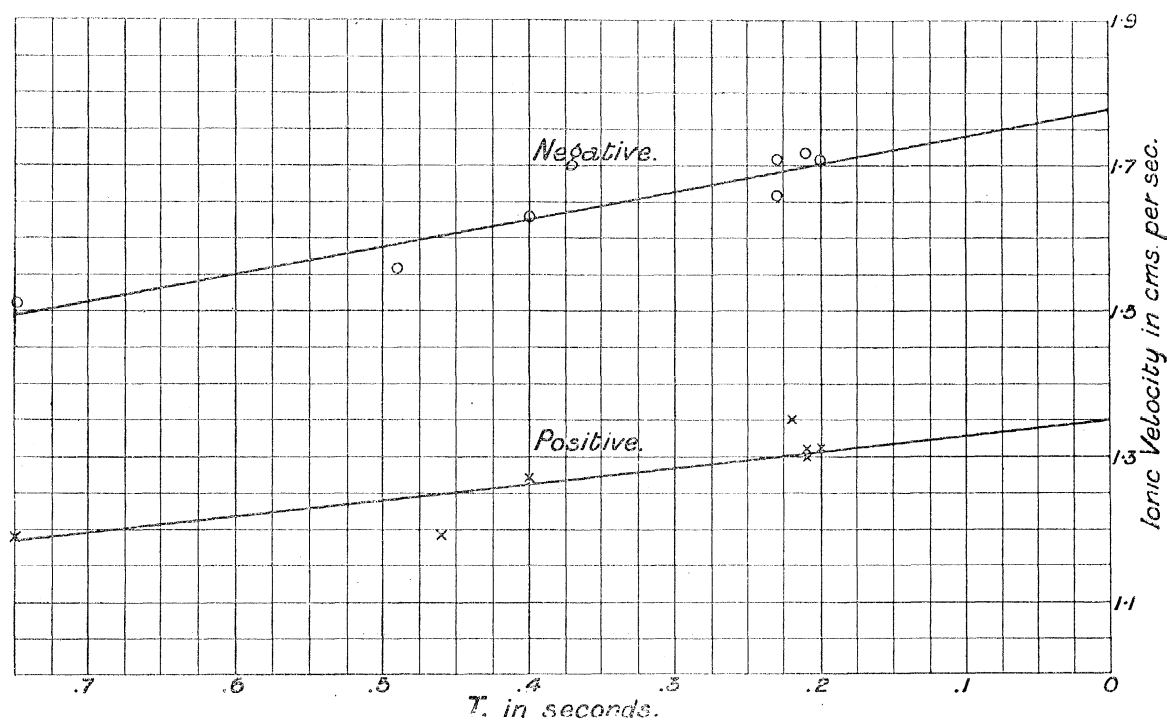

Fig. 12.

§ 10. CARBONIC ACID.

The gas used was taken from a cylinder of liquid carbonic acid. The small amount of impurities in this does not produce any marked change in the density of the gas, and is assumed to be without noticeable effect upon the ionic velocities. As examples of the readings taken, the following two sets are given for carbonic acid gas saturated with aqueous vapour :—

Temperature = 16.3° C. $X = 3.02$ centims. Barometer = 75.4 centims.

Excess pressure in gasometer = $.44$ centim.

„ „ „ apparatus = $.21$ „

10 cells = 20.6 volts.

TABLE XIII.—Moist Carbonic Acid. Negative Ions.

Voltage of outer cylinder.	Electrometer deflection in 30 seconds.	Descent of gasometer in 40 seconds.
Cells.	Divisions.	Centims.
— 6	136	2.34
— 7	106.5	2.33
— 8	76	2.33
— 9	41.5	2.30
— 10	17.5	2.33
— 9.4	28	2.29
— 8.4	57	2.28
— 7.4	91.5	2.27

The results are shown in Curve I. of fig. 13.

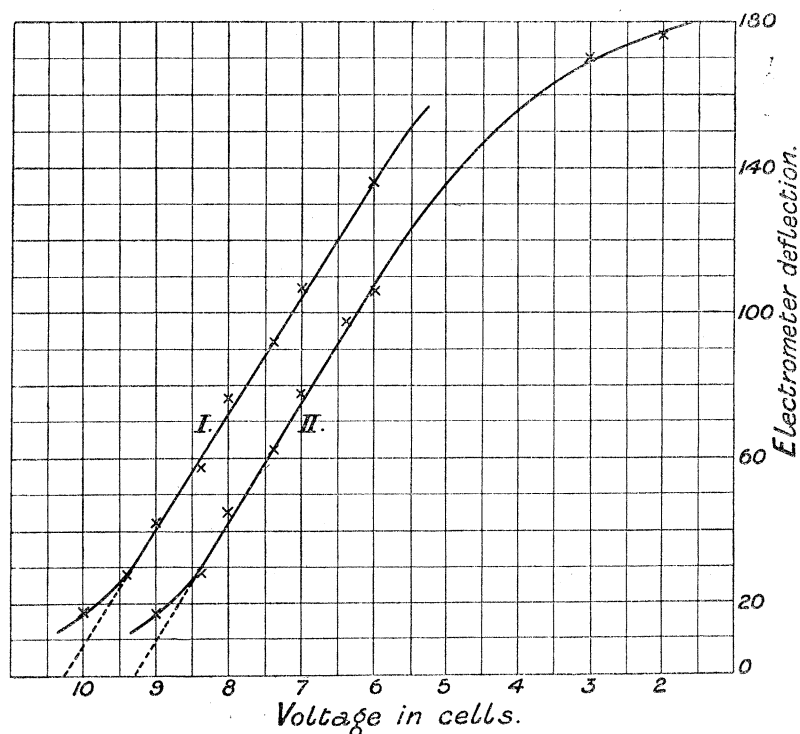

Fig. 13.

The corrected value of $U = 8.52$ centims. per second.

$$A = 21.1 \text{ volts.}$$

$$v = 5.118 \frac{8.52}{3.02 \times 21.1} = .683 \text{ centim. per second, which, reduced to 76 centims. pressure, becomes } .679 \text{ centim. per second.}$$

$$T = \frac{3.02}{8.52} = .36 \text{ second.}$$

TABLE XIV.—Moist Carbonic Acid. Positive Ions.

Voltage of outer cylinder.	Electrometer deflection in 30 seconds.	Descent of gasometer in 40 seconds.
Cells.	Divisions.	Centims.
+2	176.5	2.32
+3	170	2.31
+6	106	2.33
+7	77.5	2.32
+8	45	2.32
+9	17	2.32
+8.4	28	2.26
+7.4	62	2.25
+6.4	97.5	2.27

These results are represented in curve II. of fig. 13.

The corrected value of $U = 8.48$ centims. per second.

$$A = 19.16 \text{ volts.}$$

$$v = 5.118 \frac{8.48}{3.02 \times 19.16} = .749 \text{ centim. per second, which reduced to } 76 \text{ centims.}$$

pressure becomes .745 centim. per second.

$$T = \frac{3.02}{8.48} = .36 \text{ second.}$$

A summary of the results for moist carbonic acid is given in Table XV.

TABLE XV.—Moist Carbonic Acid. Summary of Results.

Reference number.	X.	U.	A.	T.	Temperature.	Gas pressure.	Ionic velocity.	
							Negative.	Positive.
					° C.			
1	3.02	8.48	+19.16	.36	16.3	75.6	—	.745
2	3.02	8.52	-21.1	.36	16.3	75.6	.679	—
3	3.02	16.6	-39.2	.18	16.6	76.2	.717	—
4	3.02	16.75	+35.9	.18	16.6	76.2	—	.791
5	6.07	9.74	-12.3	.62	16.9	75	.658	—
6	6.07	9.97	+11	.61	16.9	75	—	.755
7	6.07	19.4	+21.5	.31	17.1	75.5	—	.755
8	6.07	18.1	-22.14	.33	17.1	75.5	.685	—
9	6.07	8.63	+9.95	.70	17.1	75	—	.722
10	6.07	13.05	+14.1	.47	17.6	75.1	—	.772
11	6.07	12.9	-15.85	.47	17.6	75.1	.678	—

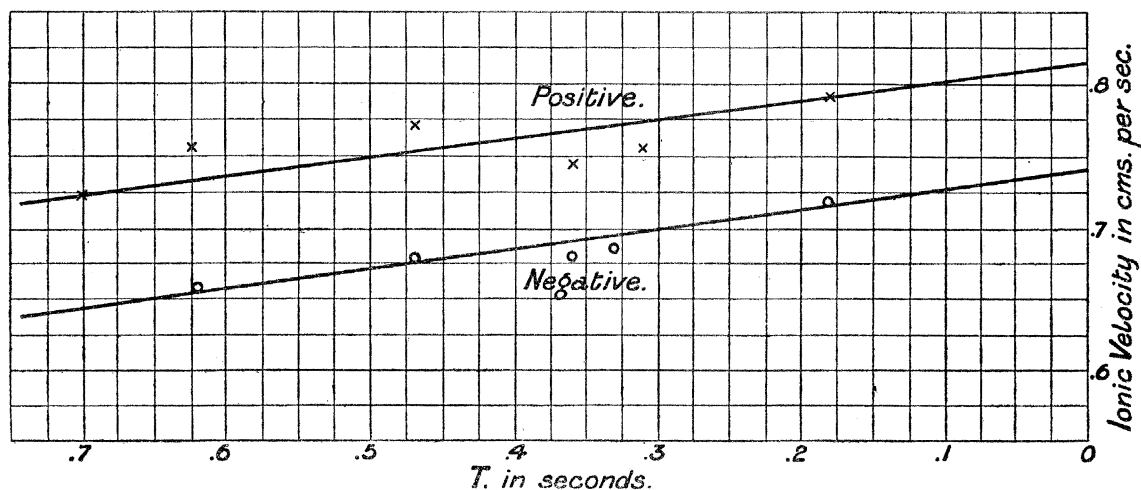

Fig. 14.

The results are represented in fig. 14, from which it is seen that the values corresponding to $T = 0$, when corrected similarly to those of moist oxygen, give as the velocity in moist carbonic acid, for the negative ions, .75 centim. per second, and

for the positive ions, .825 centim. per second, for a pressure of 76 centims. and a temperature of about 17° C.

A summary of the results obtained for dry carbonic acid is given in Table XVI.

TABLE XVI.—Dry Carbonic Acid. Summary of Results.

Reference number.	X.	U.	A.	T.	Temperature.	Gas pressure.	Ionic Velocity.	
							Negative.	Positive.
					° C.			
1	6.07	8.61	- 9.15	.71	17.5	75.4	.787	—
2	6.07	8.63	+ 9.59	.71	17.5	75.4	—	.752
3	6.07	16.7	+ 19.07	.36	17.5	75.8	—	.737
4	6.07	17.1	- 18.05	.36	17.5	75.8	.796	—
5	3.08	17.3	- 36.2	.18	18.3	75.8	.793	—
6	3.08	17.3	+ 38.4	.18	18.3	75.8	—	.747
7	3.08	8.25	+ 18.96	.37	17.2	75.7	—	.725
8	3.08	8.53	- 18.18	.36	17.2	75.7	.781	—
9	6.01	8.63	- 9.53	.70	17.3	75.7	.770	—
10	6.01	8.53	+ 9.64	.71	17.3	75.7	—	.753
11	6.01	12.8	+ 14.76	.47	17.5	75.9	—	.738
12	6.01	12.85	- 14.04	.47	17.5	75.9	.777	—

The results are represented in fig. 15.

The velocities appear to vary but little with T.

The values for the positive velocity being comparatively large for the highest value of T, make it difficult to draw the line through the positive points, and the inclination of the one through the negative points has been used as a guide for drawing the one shown. The value thus found, when corrected, gives the velocity in dry carbonic acid for the negative ions as .81 centim. per second, and for the positive ions as .76 centim. per second for a pressure of 76 centims. and a temperature of 17.5° C.

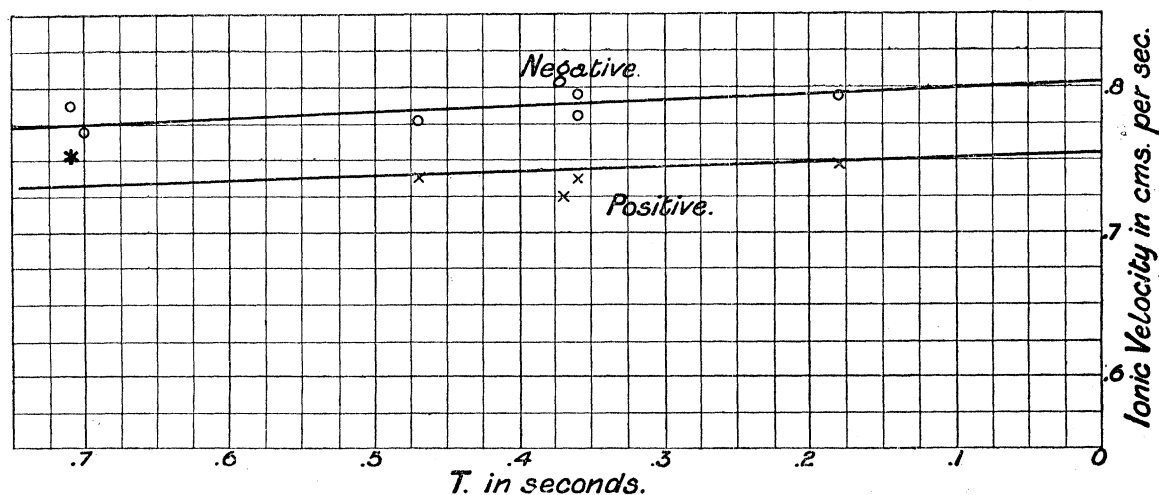

Fig. 15.

§ 11. HYDROGEN.

The gas was prepared from pure zinc and hydrochloric acid, and bubbled through three bottles of strong caustic potash and potassium permanganate to free it from the acid and other impurities. Great difficulty was experienced in maintaining the gas sufficiently pure on standing, because of the large surface of rubber exposed in the gas bag and in the connecting tubes of the apparatus. The density of hydrogen being so small compared to that of air, a small amount of the latter produces a large change in the density of the gas, and it was found that the ionic velocities were greatly affected thereby.

The following plan was finally adopted as the most practicable under the circumstances :—

The forenoon of a day was spent in the preparation of fresh hydrogen, this length of time being required to generate the large quantity necessary for use and for washing the more impure hydrogen out of the apparatus. Beginning early in the afternoon, readings were taken as rapidly as possible until after midnight, thus giving about eleven hours of continuous observations. The density of the gas was then determined by weighing a 600 cubic centims. flask filled first with dry air and then with dry gas from the gasometer. Since 1 per cent. of air in the gas made a difference of over 6 milligrams in the weight, this permitted a sufficiently accurate determination of the amount of the air impurity. A test was made by the eudiometer method, which showed that the impurity was practically all air.

The width of the beam of rays used was $\cdot 3$ centim., as the conductivity was much less with the hydrogen than in the other cases.

The following is a set of readings taken for the negative ions in dry hydrogen :—

Temperature = 20° C. $X = 2\cdot 95$ centims. Barometer = $76\cdot 15$ centims.
 Excess pressure in gasometer = $\cdot 90$ centim.
 ” ” apparatus = $\cdot 36$ centim.
 5 cells = $10\cdot 5$ volts.

TABLE XVII.—Dry Hydrogen. Negative Ions.

Voltage of outer cylinder.	Electrometer deflection in 30 seconds.	Descent of gasometer in 40 seconds.
Cells.	Divisions.	Centims.
— 2·6	12·5	9·59
— 3	9·7	9·52
— 3·4	6·5	9·31
— 3·8	3·8	9·44
— 3·6	6	9·46
— 3·2	8·8	9·50
— 2·8	11·2	9·38
— 2·4	14·2	9·40

The results are shown graphically in curve II. of fig. 16.

The corrected value of $U = 35.0$ centims. per second.

$$A = 9.04 \text{ volts.}$$

$$v = 5.118 \frac{35}{2.95 \times 9.04} = 6.72 \text{ centims. per second, which reduced to } 76 \text{ centims.}$$

pressure becomes 6.76 centims. per second.

$$T = \frac{2.95}{35} = .084 \text{ second.}$$

The gas in this case contained 3.4 per cent. of air.

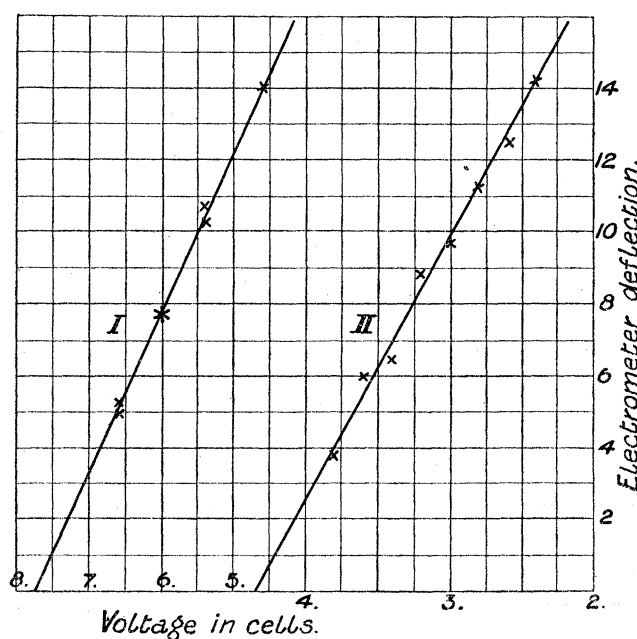

Fig. 16.

The following set of readings was taken for the positive ions in hydrogen saturated with aqueous vapour :—

Temperature = 20° C. $X = 2.95$ centims. Barometer = 76.7 centims.

Excess pressure in gasometer = $.78$ centim.

„ „ apparatus = $.35$ centim.

9 cells = 18.5 volts.

TABLE XVIII.—Moist Hydrogen. Positive Ions.

Voltage of outer cylinder.	Electrometer deflection in 30 seconds.	Descent of gasometer in 40 seconds.
Cells.	Divisions.	Centims.
+ 6·6	5·25	10·38
+ 6	7·75	10·23
+ 5·4	10·25	10·18
+ 4·6	14	10·38
+ 5·4	10·75	10·25
+ 6	7·75	10·18
+ 6·6	5	10·16

The results are shown in curve I. of fig. 16.

The corrected value of $U = 43·3$ centims. per second.

$$A = 15·9 \text{ volts.}$$

$$v = 5·118 \frac{43·3}{2·95 \times 15·9} = 4·73 \text{ centims. per second, which reduced to 76 centims. pressure,} = 4·80 \text{ centims. per second.}$$

$$T = \frac{2·95}{43·3} = ·068 \text{ second.}$$

Besides the water vapour, the gas in this case contained 1·5 per cent. of air.

A summary of the results obtained with dry hydrogen containing 3·4 per cent. of air is given in Table XIX. On account of the smaller electrometer readings the

TABLE XIX.—Dry Hydrogen. Summary of Results.

Reference number.	X.	U.	A.	T.	Temperature.	Gas pressure.	Ionic velocity.	
							Negative.	Positive.
1	2·95	21·2	+ 6·65	·14	° C. 21·4	76·3	—	5·56
2	2·95	21·6	+ 7·73	·14	21·4	76·3	—	5·15
3	2·95	21·8	+ 7·14	·14	21·4	76·3	—	5·33
4	2·95	21·9	+ 7·37	·14	21·4	76·3	—	5·18
5	2·95	21·6	- 5·79	·14	21·4	76·3	6·52	—
6	2·95	21·4	- 5·75	·14	21·4	76·3	6·49	—
7	2·95	21·4	- 5·85	·14	21·4	76·3	6·39	—
8	2·95	21·4	+ 7·14	·14	21·4	76·3	—	5·24
9	2·95	35·4	+ 10·35	·083	20	76·5	—	5·97
10	2·95	35·3	+ 10·79	·083	20	76·5	—	5·71
11	2·95	35·0	- 9·03	·084	20	76·5	6·77	—
12	2·95	35·0	- 9·24	·084	20	76·5	6·60	—
13	2·95	34·9	- 8·90	·084	20	76·5	6·84	—
14	2·95	34·7	+ 11·10	·085	20	76·5	—	5·45
15	2·95	25·7	+ 8·08	·115	20	76·4	—	5·55
16	2·95	25·7	+ 7·90	·115	20	76·4	—	5·67

determinations for hydrogen are less accurate, and so results were obtained for small values of T , only because of their greater importance, and in order to expedite the readings.

The results are represented by I. and II. of fig. 17.

The lines projected to $T = 0$ indicate for the uncorrected velocity of the negative ions 7.3 centims. per second, and for the positive ions 6.2 centims. per second when under a pressure of 76 centims., and at a temperature of about 20° C. These values are for dry hydrogen containing 3.4 per cent. of air. The correction for the presence of the air can be found approximately by finding the value of the velocity in a gas having a larger percentage of air.

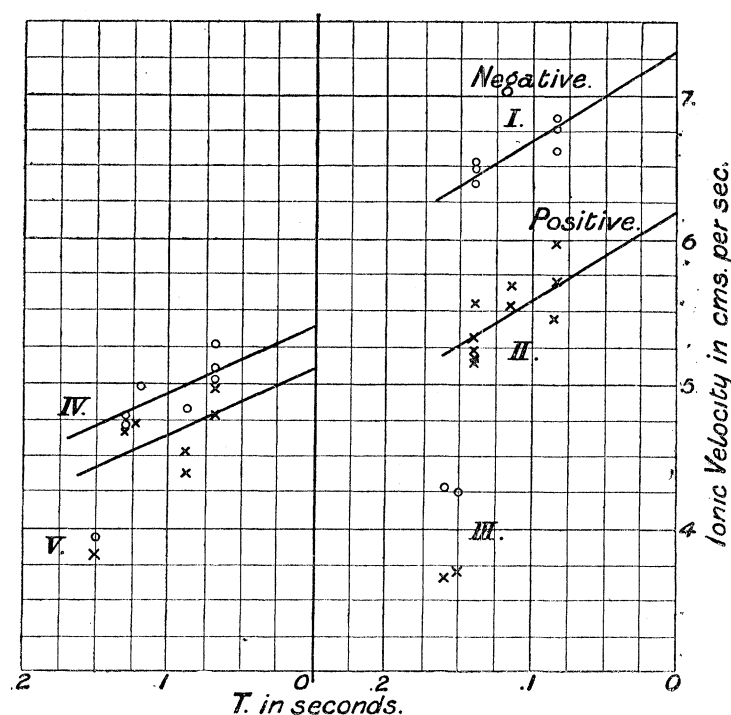

Fig. 17.

The following are a number of results obtained with dry hydrogen which contained 14.4 per cent. of air :—

TABLE XX.—Dry Hydrogen with 14.4 per cent. of Air.

Reference number.	X.	U.	A.	T.	Temperature.	Gas pressure.	Ionic velocity.	
							Negative.	Positive.
1	2.95	20.4	+ 9.62	.15	$^{\circ}$ C. 21.2	76.3	—	3.70
2	2.95	20.2	- 8.28	.15	21.2	76.3	4.25	—
3	2.95	18.6	- 7.59	.16	22	76.4	4.27	—
4	2.95	18.6	+ 8.90	.16	22	76.4	—	3.65

These results are represented at III. in fig. 17.

By finding the difference between these points and the values in the curves above them corresponding to the same value of T, the diminution in the velocity is obtained that is produced by the addition of $14.4 - 3.4 = 11$ per cent. of air. Assuming that up to this point the diminution in the ionic velocity is proportional to the amount of air present in the gas, the velocity in pure hydrogen is found by adding to the value obtained when 3.4 per cent. of air was present $\frac{3.4}{11}$ part of the diminution observed as due to 11 per cent. of air. From the above results this correction is found to be .65 for the negative ions and .50 for the positive ions. Disregarding any minor corrections, the final result for pure dry hydrogen is thus found to be 7.95 centims. per second for the negative ions, and 6.70 centims. per second for the positive ions at a pressure of 76 centims., and at a temperature of about 20° C.

A summary of the results obtained with hydrogen saturated with aqueous vapour, and containing 1.5 per cent. of air, is given in Table XXI.

TABLE XXI.—Moist Hydrogen. Summary of Results.

Reference number.	X.	U.	A.	T.	Temperature.	Gas pressure.	Ionic velocity.	
							Negative.	Positive.
1	2.95	43.9	-14.6	.067	°C. 20	77.1	5.26	—
2	2.95	43.7	-15.0	.067	20	77.1	5.10	—
3	2.95	43.7	+15.5	.067	20	77.1	—	4.97
4	2.95	43.3	+15.9	.068	20	77.1	—	4.80
5	2.95	43.1	-15.0	.069	20	77.1	5.03	—
6	2.95	23.8	-8.43	.12	19.8	76.9	4.98	—
7	2.95	23.5	-8.76	.13	19.8	76.9	4.72	—
8	2.95	23.4	-8.64	.13	19.8	76.9	4.77	—
9	2.95	23.3	+8.77	.13	19.8	76.9	—	4.68
10	2.95	23.3	+8.69	.13	19.8	76.9	—	4.73
11	2.95	34.2	+13.3	.087	19.8	77	—	4.53
12	2.95	34.1	+13.8	.087	19.8	77	—	4.37
13	2.95	34	-12.4	.087	19.8	77	4.82	—
14	2.98	19.8	-8.74	.15	20.4	76.7	3.93	—
15	2.98	19.7	+8.97	.15	20.7	76.9	—	3.82

The results 1 to 13 are represented by IV. of fig. 17.

The results 14 and 15 were obtained with moist hydrogen containing 8 per cent. of air. These two were selected out of a number of results of which they represent about the average values. They are shown by V. of fig. 17, and by means of them the correction for the air present in the above experiments was made in the same manner as with dry hydrogen. The points IV. in the figure are so scattered that the inclination of the lines drawn through them had to be estimated mainly by comparison with those for dry hydrogen, remembering that with the smaller

velocities here obtained the inclination would be somewhat less. The final values thus obtained for hydrogen saturated with aqueous vapour when corrected for the air present give for the velocity of the negative ions 5.6 centims. per second, and for the positive ions 5.3 centims. per second at a pressure of 76 centims., and a temperature of 20° C.

§ 12. REMARKS ON THE EXPERIMENTS.

The changes in the values obtained for the velocity with changes of T are observed to be greater for those cases where the ionic velocities are higher. With dry and moist carbonic acid, however, the inclination of the curves is somewhat different for nearly equal values of the velocities. In some instances, where the set of points for either the positive or the negative ions did not allow of a sufficiently accurate estimate of the inclination of the line to be drawn through them, the line through the other set of points was used as a guide.

The presence of water vapour diminished the velocity of the negative ions in all of the gases, while in carbonic acid the velocity of the positive ions was at the same time considerably increased. It seems most probable that these changes are due to some effect upon the size of the ions, and it is possible that a few molecules of the aqueous vapour collect upon the negative ions. It is interesting to note in this connection the recent results of C. T. R. WILSON,* showing that in supersaturated air the water condenses more readily upon the negatively charged ions.

While in most cases the readings indicate a greater accuracy, it is believed that the maximum error in any determination is less than five per cent. For convenience, all of the values obtained are here collected in one table, the results being given in centims. per second both for a field of one volt per centim. and for a field of one electrostatic unit per centim.

TABLE XXII.—Ionic Velocities.

Gas.	Velocities in centims. per second in a field of 1 volt per centim.		Velocities in centims. per second in a field of 1 E.S.U. per centim.		Ratio of Negative to Positive.	Temperature.
	Positive ions.	Negative ions.	Positive ions.	Negative ions.		
Air, dry	1.36	1.87	408	561	1.375	° C. 13.5
„ moist	1.37	1.51	411	453	1.10	14
Oxygen, dry	1.36	1.80	408	540	1.32	17
„ moist	1.29	1.52	387	456	1.18	16
Carbonic acid, dry76	.81	228	243	1.07	17.5
„ moist82	.75	246	225	.915	17
Hydrogen, dry	6.70	7.95	2010	2385	1.19	20
„ moist	5.30	5.60	1590	1680	1.05	20

* C. T. R. WILSON, 'Phil. Trans.,' A, vol. 193, p. 289, 1899.

It is seen that the value of the velocity is greater for the negative ions in all cases except for moist carbonic acid. In comparing the values for the different gases, the temperature at which the observations were taken must be taken into consideration.

At the time the writer* determined the ratio of these velocities, the influence of moisture being unknown, the gases used were not dried, and so the values obtained were between those given above for the dry and the moist gases. Of the gases used in the former experiments, which were not used in these, the ammonia gas used had been passed through two long tubes of calcium oxide, the acetylene gas had been passed through a long tube of calcium carbide and the nitrogen monoxide was used directly from a cylinder.

The results obtained by E. RUTHERFORD† for the sum of the velocities of the ions produced by Röntgen rays are for :—

Air =	3·2 centims. per second.
Oxygen =	2·8 centims. per second.
Carbonic acid =	2·15 centims. per second.
Hydrogen =	10·4 centims. per second.

It is not stated whether the gases were dried, but the value for air agrees with that given above for the sum of the velocities in dry air, while the values for oxygen and hydrogen agree with the values for the moist gases. The value for carbonic acid is nearly 40 per cent. larger than that obtained here. It is of interest to compare the velocities of the ions produced by Röntgen rays with those of the ions produced by the action of ultra-violet light and in the discharge from points, as they show a close similarity.

For conduction produced by ultra-violet light, E. RUTHERFORD‡ obtained with dry gases for the velocity of the negative ions in—

Air =	1·4 centims. per second.
Hydrogen =	3·9 centims. per second.
Carbonic acid =	·78 centim. per second.

The value for carbonic acid is quite near to that obtained above, but the other two are considerably smaller.

A. P. CHATTOCK§ obtained for the velocities of the ions in dry air in the case of discharge from points—

413	centims.	per second	for the	positive	ions,	and
540	„	„	„	negative	ions	for a field of one electrostatic unit.

* J. ZELENY, 'Phil. Mag.,' July, 1898.

† E. RUTHERFORD, 'Phil. Mag.,' November, 1897.

‡ E. RUTHERFORD, 'Proc. Camb. Phil. Soc.,' vol. 9, Pt. VIII.

§ A. P. CHATTOCK, 'Phil. Mag.,' November, 1899.

These values are nearly the same as those obtained above for the ions produced by Röntgen rays.

J. S. TOWNSEND* has shown that from the ionic velocity in a gas and the coefficient of diffusion of the ions in the gas, the value of Ne can be obtained, N being the number of molecules in a cubic centim. of the gas, and e the charge carried by an ion. By comparing this value with that obtained from the electrolysis of liquids, the relation between the charges on the ions in the two cases can be determined.

Using the values of the ionic velocities (v) given in Table XXII., and the corresponding coefficients of diffusion (K) from the tables given by J. S. TOWNSEND, the values of Ne are obtained from the equation $Ne = \frac{3 \times 10^8 v}{K}$ for the positive and the negative ions in both dry and moist gases.

The results are given in the following table:—

TABLE XXIII.—Values of Ne $\times 10^{-10}$.

Gas.	Moist gas.		Dry gas.	
	Positive ions.	Negative ions.	Positive ions.	Negative ions.
Air.....	1·28	1·29	1·46	1·31
Oxygen	1·34	1·27	1·63	1·36
Hydrogen	1·24	1·18	1·63	1·25
Carbonic acid	1·01	·87	·99	·93

The corresponding value of Ne obtained for hydrogen from the electrolysis of liquids is $1\cdot23 \times 10^{10}$ at a pressure of 76 centims. of mercury, and a temperature of 15° C.

The values of Ne in the table for the positive and the negative ions in moist air, oxygen and hydrogen are perhaps in sufficient agreement to justify the statement that the charges carried by the positive and negative ions are the same, and that the value is also the same for the three gases, and corresponds to the charge carried by the hydrogen ion in the electrolysis of liquids.

The values of Ne for the negative ions in the same three gases when dry are not far from those in the moist gases, but the results for the positive ions are considerably larger. It seems very improbable, however, that the charges carried by the ions are different in the moist and dry gases, since most likely the moisture does not influence the act of the ionization itself, but either affects the ions after they are formed during the production of clusters of molecules around them, or changes the resistance

* J. S. TOWNSEND, 'Phil. Trans.,' A, vol. 193, p. 152.

to their motion. So if the charges are equal in the moist gases, they should be equal in the dry gases also.

The values of N_e for carbonic acid are all less than that obtained for hydrogen by electrolysis, and so indicate a smaller charge on the ions; but from analogy with liquids we should expect that if the charges vary at all, it would be in the ratio of one to two or more, unless it is possible to have a charge smaller than that carried by hydrogen in electrolysis.

The writer cannot account for the differences in the values of N_e by supposing them due to errors in the ionic velocities obtained, since that would mean the presence in the experiments of some error which in some cases influenced the results for the positive ions alone, in other cases had an effect upon the values of both of the ions, and in still other cases was without effect.

The experiments described in this paper were performed at the Cavendish Laboratory, Cambridge, and I desire to express here my thanks to Professor J. J. THOMSON for the encouragement and valuable suggestions given in the course of the investigation.